

## Top View

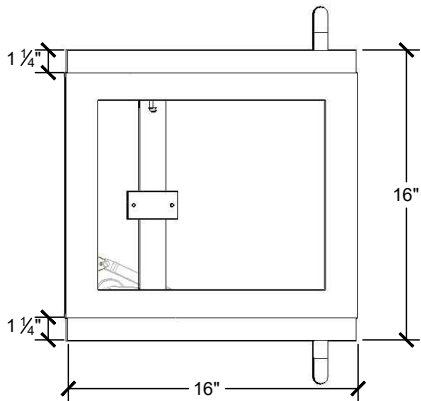

## Front View

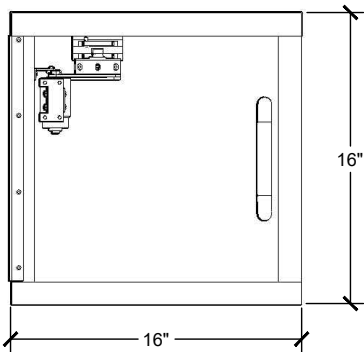

## Material Notes

1. 18 Gauge stainless steel top cover.
2. Aluminum brushed pull handle.
3. 1 1/4" Bullet resistant cast acrylic. Options of either level 1 or 3.
4. Hydraulic power-closer. Providing full ballistic protection, while unit is in use.
5. Interlocking door mechanism, allows for only one door to open at a time.
6. 18 gauge stainless steel bottom cover.

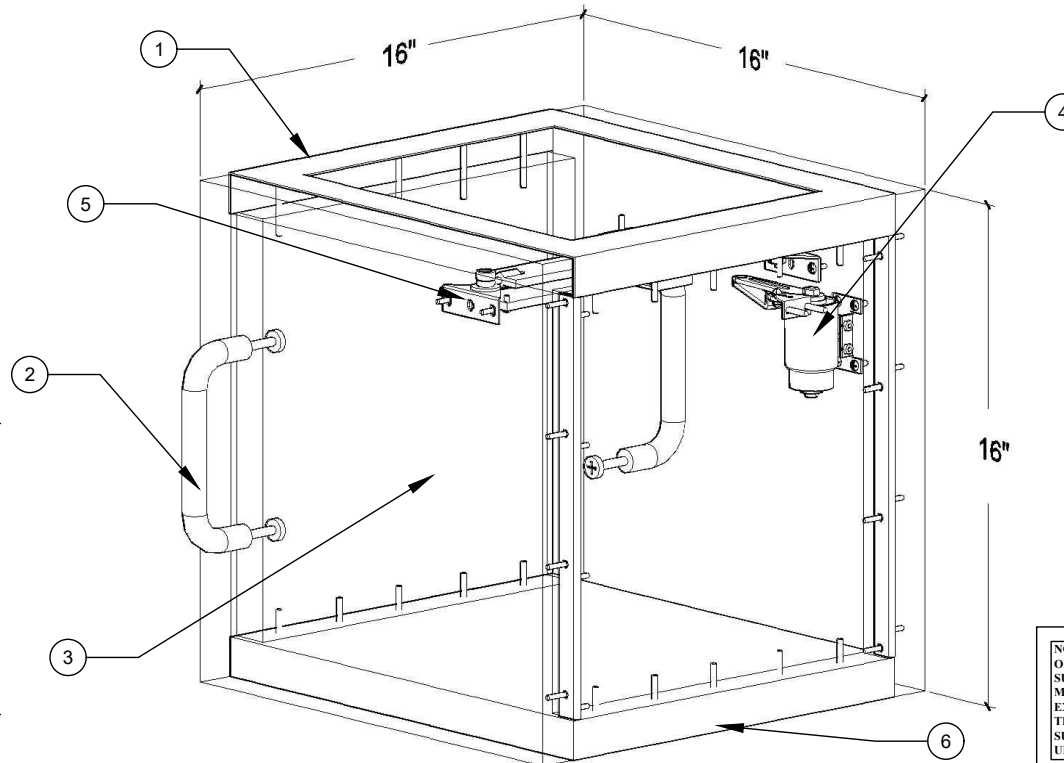

**CE** COVENANT  
Security Equipment  
9323 N Government Way  
Hayden, ID 83835

PROJECT NAME: \_\_\_\_\_

SIGNATURE: \_\_\_\_\_

DATE: \_\_\_\_\_

Approved as Drawn

Approved as Noted

### PLEASE SELECT:

#### 1. GLAZING:

LEVEL I

LEVEL II

#### 2. PLACEMENT OF HANDLE FORM INTERIOR VIEW:

LEFT

RIGHT

### Key Notes

UNIT: PR-1616

Actual Dimension  
16"(W) x 16"(H)

Transfer Area  
13 1/2"(W) x 13 1/2"(H) x 13 1/2"(D)

Rough Opening  
16 5/16"(W) x 16 5/16"(H)

### Engineer Notes

Date drawn: 5/4/17

Drawn by: C.S.

File name: CSE-QS-PR-1616\_THREE\_SIDE\_VIEW.pdf

NOTE: THIS DRAWING EMBODIES A CONFIDENTIAL PROPRIETY DESIGN ORIGINATED AND OWNED BY COVENANT SECURITY EQUIPMENT SUBMITTED UNDER A CONFIDENTIAL RELATIONS ALL PATENT, MANUFACTURING, SALE RIGHTS REGARDING THE SAME ARE RESERVED EXCEPT TO THE EXTENT RIGHTS ARE EXPRESSLY GRANTED TO OTHERS. THE RECIPIENT AGREES BY ACCEPTING HIP. THESE DRAWINGS NOT TO SUPPLY OR DISCLOSE ANY INFORMATION REGARDING THEM TO ANY UNAUTHORIZED PERSON.