

Top View

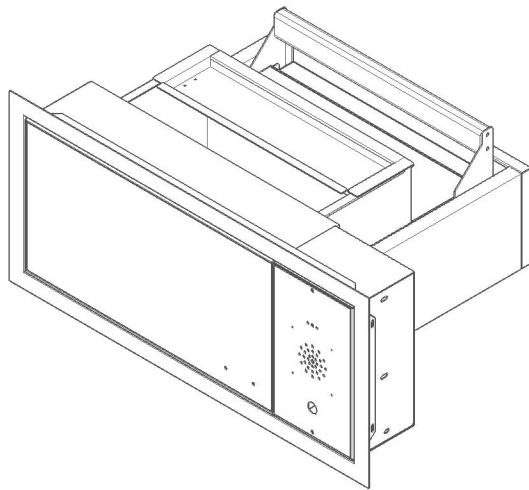

Exterior Back View

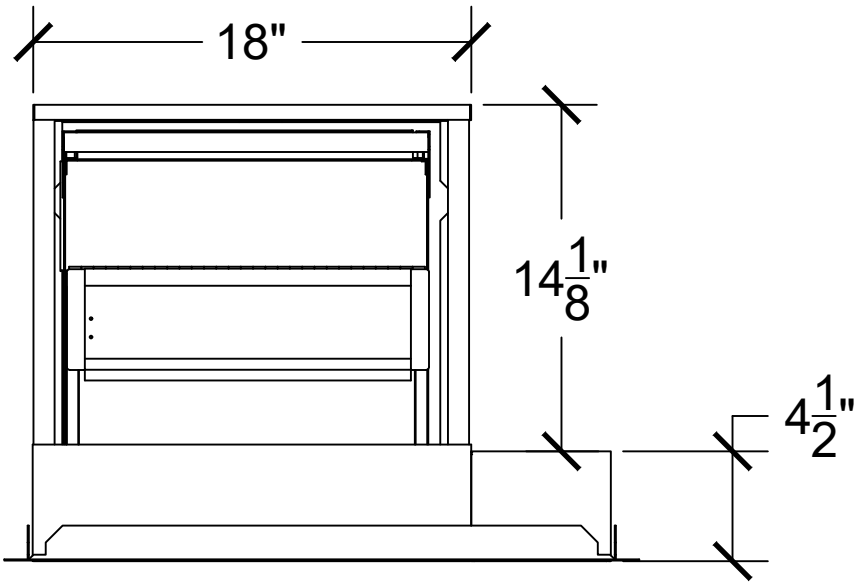
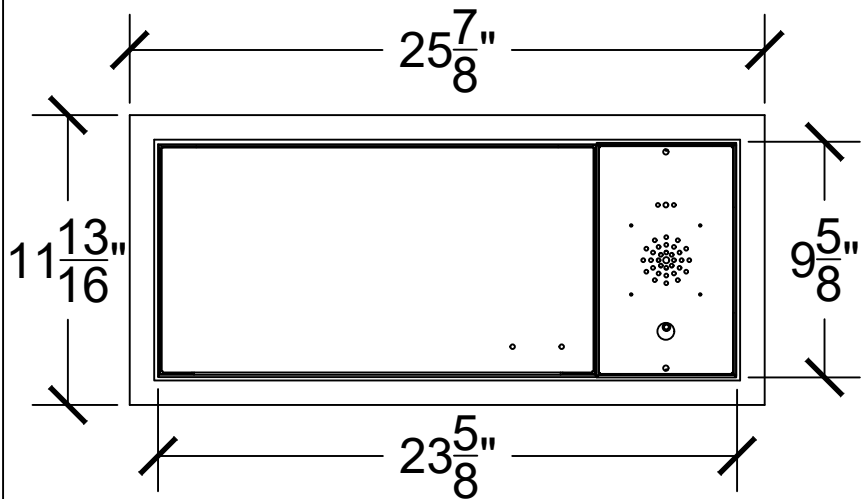

Side View

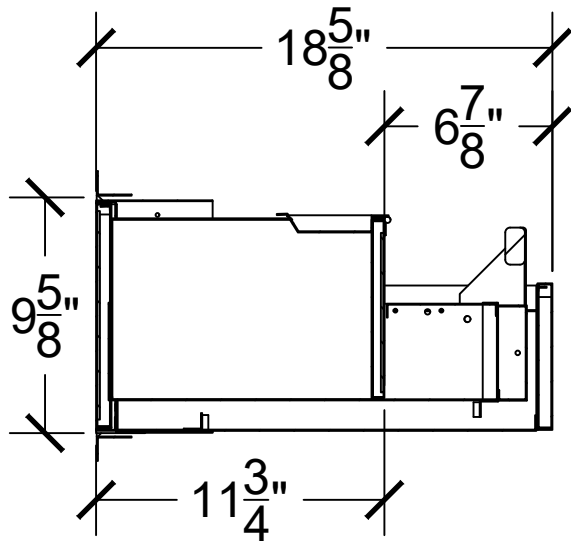

Key Notes

Unit:
 QST-1019S
 WITH FLANGE
Actual Dimension without flange:
 23-5/8"(W) x 9-5/8"(H)

Engineer Notes

Date drawn: 8/24/2021
 Drawn by: Avasquez
 File name: QST-1019S.dwg

Page: 1 of 1 Scale: 1:8

NOTE: THIS DRAWING EMBODIES A CONFIDENTIAL PROPRIETY DESIGN ORIGINATED AND OWNED BY COVENANT SECURITY. SUBMITTED UNDER A CONFIDENTIAL RELATIONS ALL PATENT, MANUFACTURING, SALE RIGHTS REGARDING THE SAME ARE RESERVED EXCEPT TO THE EXTENT RIGHTS ARE EXPRESSLY GRANTED TO OTHERS. THE RECIPIENT AGREES BY ACCEPTING THESE DRAWINGS NOT TO SUPPLY OR DISCLOSE ANY INFORMATION REGARDING THEM TO ANY UNAUTHORIZED PERSONAL.

SIGNATURE: _____
 DATE: _____