

# TOP VIEW

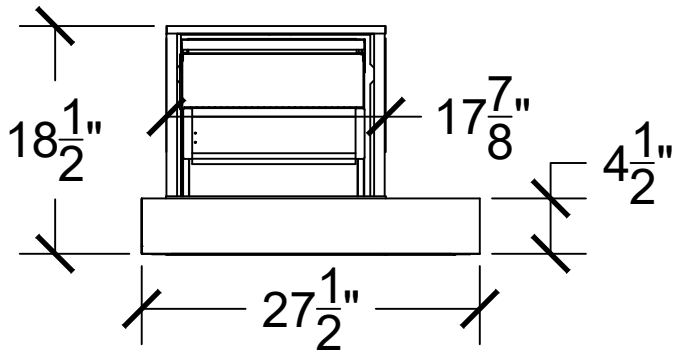

# EXTERIOR BACK VIEW

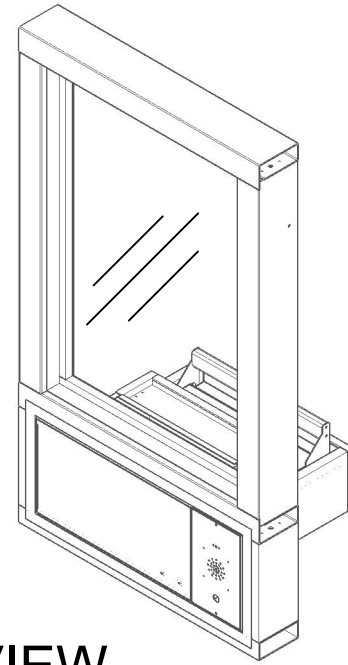
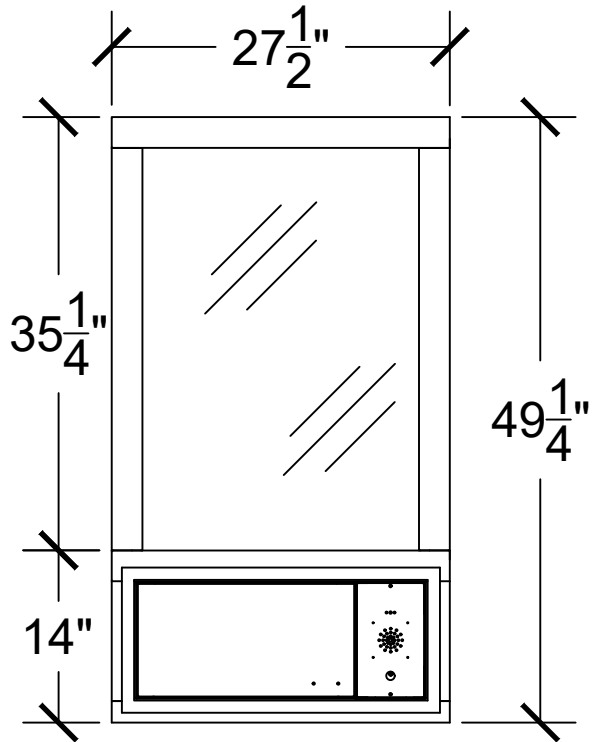

# SIDE VIEW

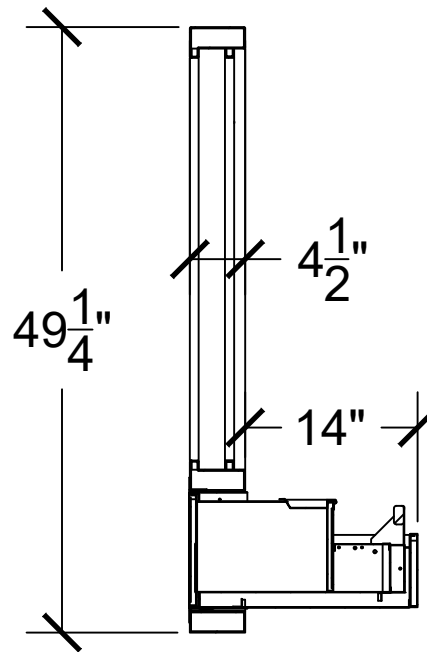

**COVENANT**  
Security Equipment

**PLEASE SELECT:**

**1. FRAMING:**

- Aluminum
- Loaded Aluminum

**2. FRAME COLOR:**

- Bronze Anodized
- Clear Anodized

Other: \_\_\_\_\_

**3. GLAZING:**

- 1" Insulated
- 3/4" Poly - L1
- 1-1/4" Acrylic - L1
- 1-1/4" Poly - L3
- 1-1/4" Acrylic - L3
- Storm Impact Low-E

Other: \_\_\_\_\_

**Key Notes**

**Unit:**

QST-1019S MINI COMBO

**Actual Dimension:**

27 <sup>1</sup>/<sub>2</sub>" (W) x 49 <sup>1</sup>/<sub>4</sub>" (H)

**Rough Opening:**

27 <sup>7</sup>/<sub>8</sub>" (W) x 49 <sup>5</sup>/<sub>8</sub>" (H)

**Engineer Notes**

Date drawn: 3/6/2020

Drawn by: Avasquez

File name: 1019S MINI COMBO.dwg

Page: 1 of 1

Scale: 1:16

NOTE: THIS DRAWING EMBODIES A CONFIDENTIAL PROPRIETY DESIGN ORIGINATED AND OWNED BY COVENANT SECURITY EQUIPMENT, AND IS SUBMITTED UNDER A CONFIDENTIAL RELATIONS ALL PATENT, MANUFACTURING, SALE RIGHTS REGARDING THE SAME ARE RESERVED EXCEPT TO THE EXTENT RIGHTS ARE EXPRESSLY GRANTED TO OTHERS. THE RECIPIENT AGREES BY ACCEPTING THESE DRAWINGS NOT TO SUPPLY OR DISCLOSE ANY INFORMATION REGARDING THEM TO ANY UNAUTHORIZED PERSONAL.

SIGNATURE: \_\_\_\_\_

DATE: \_\_\_\_\_