

Top View

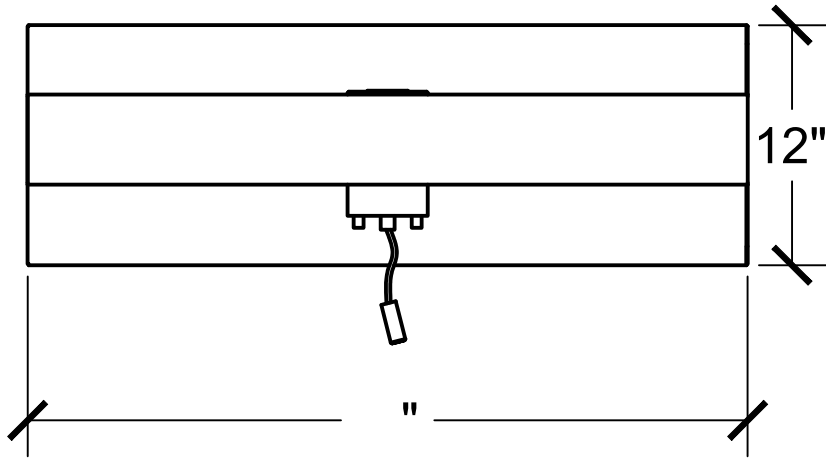

Interior Front View

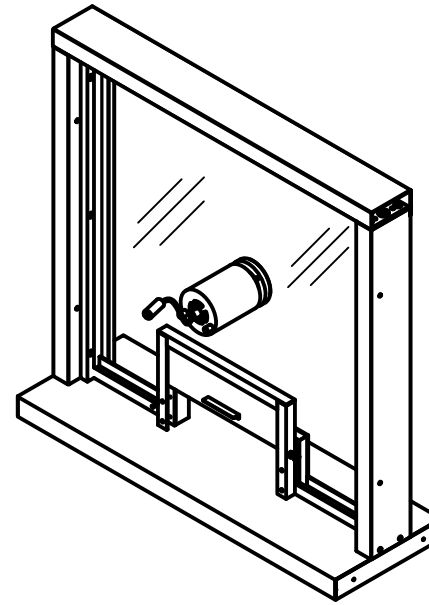
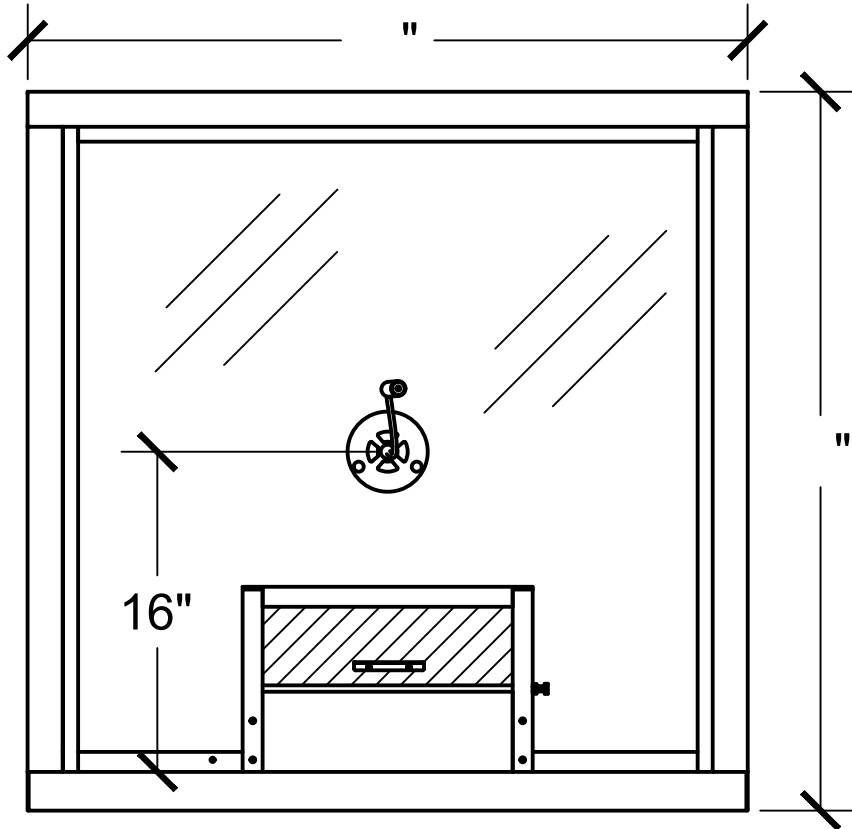

Side View

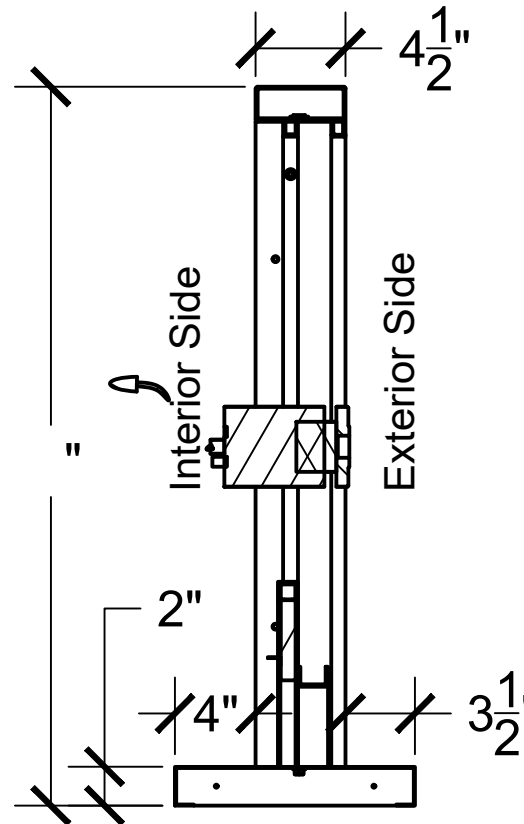

**COVENANT**  
Security Equipment

**PLEASE SELECT:**

**1. FRAMING:**

Aluminum  UL Rated Alum

UL Rated Stainless

**2. FRAME COLOR:**

Bronze Anodized  Clear Anodized

Other: \_\_\_\_\_

**3. GLAZING:**

1/4" Tempered  1" Insulated

3/4" Poly - L1  1-1/4" Acrylic - L1

1-1/4" Poly - L3  1-1/4" Acrylic - L3

Storm Impact Low-E

Other: \_\_\_\_\_

**4. SPEAKER:**

6" BR Speak-Thru (L3)

5" Non-BR Speak Plate

SC-100 Amplified  SC-100L Amplified

Speak Around

**Key Notes**

**Unit:**

Ticket Window W/ Slide-up & Amp

**Actual Dimension:**

"(W) X "(H)

**Rough Opening:**

"(W) X "(H)

**Service Opening Slide-Up:**

12"(W) X 4"(H) (GLASS IS LEVEL I 3/4")

**Engineer Notes**

Date drawn: 7/24/20

Drawn by: Avasquez

File name: FILL IN TW Slide Up Amp Cov.dwg

Page: 1 of 2

Scale: 1:10

NOTE: THIS DRAWING EMBODIES A CONFIDENTIAL PROPRIETY DESIGN ORIGINATED AND OWNED BY COVENANT SECURITY EQUIPMENT SUBMITTED UNDER A CONFIDENTIAL RELATIONS ALL PATENT, MANUFACTURING, SALE RIGHTS REGARDING THE SAME ARE RESERVED EXCEPT TO THE EXTENT RIGHTS ARE EXPRESSLY GRANTED TO OTHERS. THE RECIPIENT AGREES BY ACCEPTING HIP. THESE DRAWINGS NOT TO SUPPLY OR DISCLOSE ANY INFORMATION REGARDING THEM TO ANY UNAUTHORIZED PERSON.

SIGNATURE: \_\_\_\_\_

DATE: \_\_\_\_\_

# Interior View



**COVENANT**  
Security Equipment

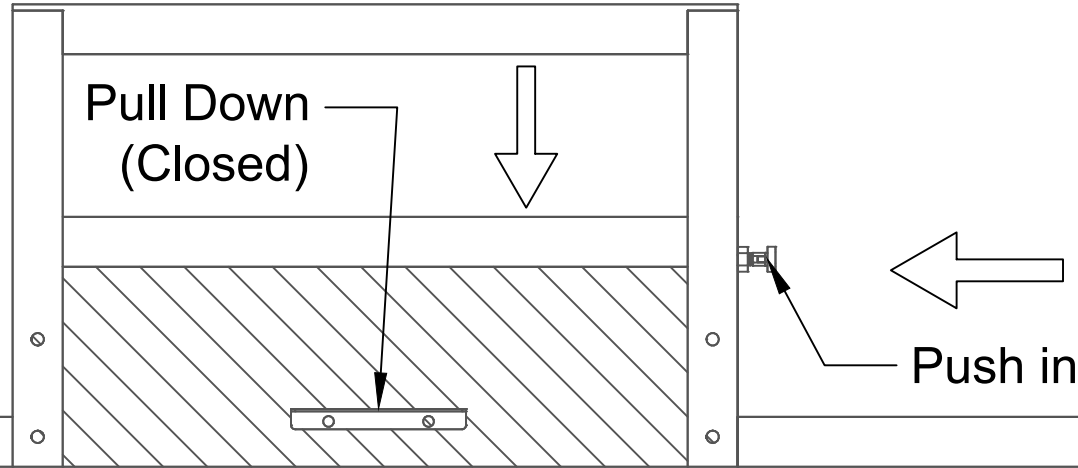

**PLEASE SELECT:**

**1. FRAMING:**

- Aluminum
- UL Rated Alum
- UL Rated Stainless

**2. FRAME COLOR:**

- Bronze Anodized
- Clear Anodized

Other: \_\_\_\_\_

**3. GLAZING:**

- 1/4" Tempered
- 1" Insulated
- 3/4" Poly - L1
- 1-1/4" Acrylic - L1
- 1-1/4" Poly - L3
- 1-1/4" Acrylic - L3
- Storm Impact Low-E

Other: \_\_\_\_\_

**4. SPEAKER:**

- 6" BR Speak-Thru (L3)
- 5" Non-BR Speak Plate
- SC-100 Amplified
- SC-100L Amplified
- Speak Around

**Key Notes**

**Unit:**

Ticket Window W/ Slide-up & Amp

**Actual Dimension:**

"(W) X "(H)

**Rough Opening:**

"(W) X "(H)

**Service Opening Slide-Up:**

12"(W) X 4"(H) (GLASS IS LEVEL I 3/4")

**Engineer Notes**

Date drawn: 7/24/20

Drawn by: Avasquez

File name: FILL IN TW Slide Up Amp Cov.dwg

Page: 2 of 2

Scale: 1:4

NOTE: THIS DRAWING EMBODIES A CONFIDENTIAL PROPRIETY DESIGN ORIGINATED AND OWNED BY COVENANT SECURITY EQUIPMENT SUBMITTED UNDER A CONFIDENTIAL RELATIONS ALL PATENT, MANUFACTURING, SALE RIGHTS REGARDING THE SAME ARE RESERVED EXCEPT TO THE EXTENT RIGHTS ARE EXPRESSLY GRANTED TO OTHERS. THE RECIPIENT AGREES BY ACCEPTING HIP. THESE DRAWINGS NOT TO SUPPLY OR DISCLOSE ANY INFORMATION REGARDING THEM TO ANY UNAUTHORIZED PERSON.

Held up  
by Magnets

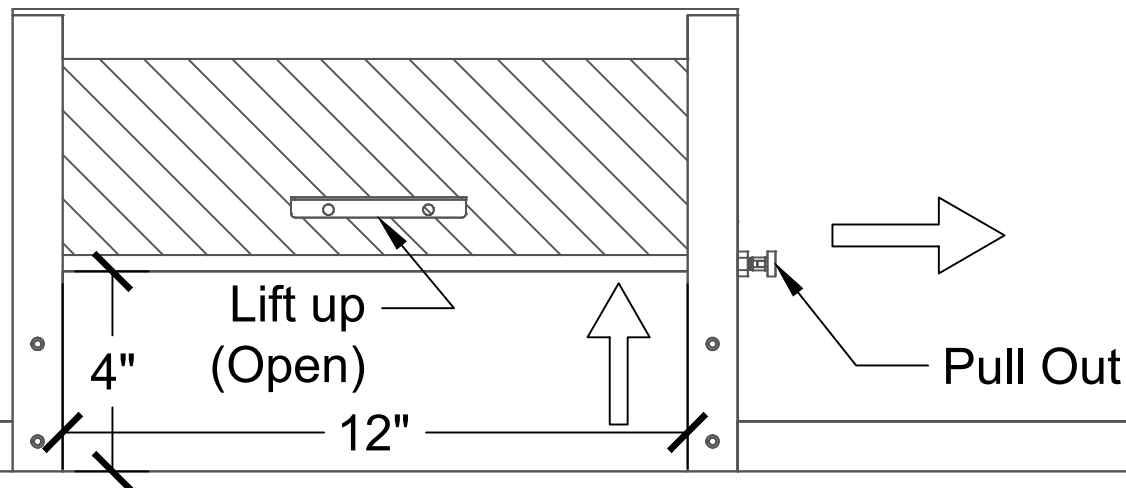

SIGNATURE: \_\_\_\_\_

DATE: \_\_\_\_\_