

**600 Series
Security Windows**



Model 600

Model 601 / 603



Model 602 / 604

**Pass-Thru Window
Manual, Self Closing, MOER,
Electric**

TABLE OF CONTENT

Topic	Page
Disclaimer	2
Serial Number Identification	2
Contact Sheet	2
Introduction	3
Product Information	4
Description	4
Specifications	9
Dimensions	10
Safety Information	13
Installation Procedures	13
Tools needed	13
Materials Needed	13
Physical Installation	14
Electrical Installation	19
Initial Operations and Testing	21
Adjustments and Calibrations	22
Operational Procedures	
Modes of Operation	26
Operations	26
Control Identification, Explanation and Function	28
Maintenance	
Maintenance Schedule	29
Daily	29
Monthly	29
Yearly	29
Service	
Troubleshooting Guide (Cause and Effect)	30
Parts Lists	
Parts List (Description/Part Number)	33
Drawings - Exploded Views / Schematics	34
Appendix "A" Adjusting or Re-hanging the Door	39

DISCLAIMER

READY ACCESS DISCLAIMS ANY LIABILITY FOR ANY DAMAGE OR HARM CAUSED TO THE MODEL 600 DRIVE-THRU WINDOW, IT'S OPERATOR OR ANY OTHER EQUIPMENT HOWEVER CAUSED IF THE MODEL 600 DRIVE-THRU WINDOW IS REPAIRED OR SERVICED BY ANYONE OTHER THAN AN AUTHORIZED SERVICE ENGINEER OR CONTRARY TO THE MANUFACTURERS WRITTEN INSTRUCTION CONTAINED HEREIN.

THIS MANUAL IS INTENDED FOR USE BY THE IN-HOUSE OR AUTHORIZED FIELD SERVICE ENGINEERS AND SALES REPRESENTATIVES

The manufacturer maintains the right to update, add or issue a new service manual at any time without notice, thereby rendering all previous issues obsolete.

Please write the Serial Number and Installation Date for your drive-thru window in the spaces provided.

Serial Number	
Date of Installation	

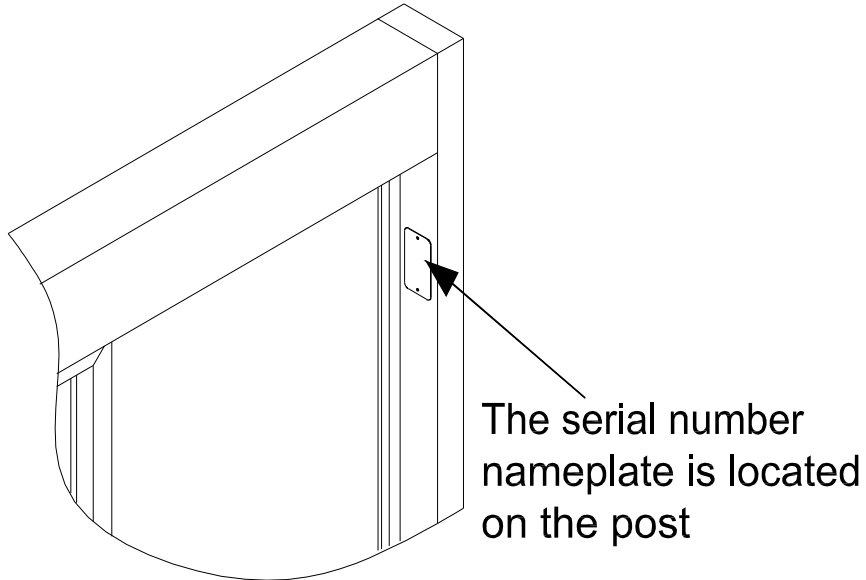

CONTACT INFORMATION FOR SALES AND SERVICE CONTACT

INTRODUCTION

The Ready Access window is quality designed to give you years of reliable, trouble-free service. Each window is shipped pre-assembled, fully glazed and ready for installation. All Ready Access windows are thoroughly tested prior to shipping.

The 600 Series of Single Door Slider Windows are the only completely modular security drive-thru system designed to meet your specific security needs. With options including a selection of security glazing and four different operating methods, this window is adaptable to your level of security needs.

The Model 600 drive-up window comes in three versions, manual open / self closing, MOER and a fully automatic / electric model. The electric version is fully automatic with a manual override in case of a power outage. The door will open and close by stepping into an out of the light beam sensor. Do not attempt to assist the window manually when in automatic mode, damage can occur to internal parts.

This attractive and economical window is ideal for a drive-thru or walk up application. The large service opening is suitable for both large and small operations. It is available in one standard width, 47 ½" and two standard window heights, 35 ¾" H and 43 ½" H.

The Model 601 drive-up window has a moveable service panel and comes in three versions, manual open / self closing, MOER and a fully automatic / electric model. The electric version is fully automatic with a manual override in case of a power outage. The door will open and close by stepping into and out of the light beam sensor. Do not attempt to assist the window manually when in automatic mode, damage can occur to internal parts.

The Model 603 has a Stationary Panel. In high-risk areas the fixed glass allows for ample visibility without the risk of face-to-face contact.

These attractive and economical windows are ideal for a drive-thru or walk up application. The large service opening is suitable for both large and small operations. It is available in one standard size, 47 ½" W x 58 ½" H x 4 ½" D, with additional heights available.

The Model 602 drive-up window has a moveable service panel and comes in three versions, manual open / self closing, MOER and a fully automatic / electric model. The electric version is fully automatic with a manual override in case of a power outage. The door will open and close by stepping into and out of the light beam sensor. Do not attempt to assist the window manually when in automatic mode, damage can occur to internal parts.

The Model 604 has a Stationary Panel. In high-risk areas the fixed glass allows for ample visibility without the risk of face-to-face contact.

These attractive and economical windows are ideal for a drive-thru or walk up application. The large service opening is suitable for both large and small operations. It is available in one standard size, 47 ¾" W x 60 ½" H x 17" D, with additional heights available.

An optional full sized stainless steel interior/exterior counter is available for most Ready Access windows.

When used with the READY ACCESS pass-thru air curtain system, the flush mounted single panel-sliding window will provide the crew and customer with comfort during winter (AA300 Only) and a bug free environment during the summer. Heated air curtain is available with 600 and 601 windows only.

PRODUCT INFORMATION

Model 600

- **The Model 600 has a moveable Service Panel.**
This offers the option of servicing customers personally. The service panel self latches each time it closes and features a deadbolt lock and night security bar for complete security during closed hours.
- **Manual/Self Closing, MOER or Electric Operations**
The Model 600 Single Door Slider keeps building costs down by offering the window in a manual/self closing or MOER operating style. Or for those who experience heavier traffic, an electric operating style is also available. Self Closing, MOER and Electric models meet health department requirements for self-closing units.
- **Ease of Operation**
In a manual/self closing and MOER operation, the inside attendant pulls the door handle, to open the door. With a fully automated operation, the operator simply steps into the presence sensor and the movable window panel will slide open. When the operator steps out of the presence sensor, the movable window panel will automatically close (same for the MOER, however the magnet will release the door and will self-close). The range for the presence sensor is adjustable to specific customer needs.
- **Quality Construction**
Anodized aluminum extrusions, stainless steel and a selection of glass options combine to give you an attractive secure window that not only enhances building exteriors, but will not rust, pit or weather. Track free bottom sill provides for a contaminant free surface.
- **Finish**
This unit is currently available in a clear or bronze anodized aluminum finish or can be powder coat painted in a rainbow of color choices.
- **Fully Assembled, Ready to Install**
Ready Access windows are shipped completely pre-assembled, and fully glazed for lower installation costs. Normal installation takes an average of two to four hours.
- **Warranty and Service Support**
Your Ready Access window comes with a one year limited warranty on parts and labor provided by a worldwide service organization.

STANDARD OPTIONS

- 2 standard window dimensions with 3 glass types are available: (See Chart on Page # 9)
- A retrofit kit is available for the Model 600 Single Door Slider that easily upgrades the window from a manual/self closing operation to a MOER or fully automatic operation.
- An inside/outside stainless steel shelf is also available.

Model 601 / 603

- **The Model 601 has a moveable Service Panel.**
This offers the option of servicing customers personally. The service panel self latches each time it closes and features a deadbolt lock and night security bar for complete security during closed hours.
- **The Model 603 has a Stationary Panel.**
In high-risk areas the fixed glass allows for ample visibility without the risk of face-to-face contact.
An optional full sized S.S. inside counter available.
- **Manual or Electric Operations.**
The Model 601 Single Door Slider helps to keep building costs down by offering the window in a manual/self closing or MOER operating styles. Or for those who experience heavier traffic, an electric operating style is also available. Self Closing, MOER and Electric models meet health department requirements for self-closing units.
- **Ease of Operation**
In a manual/self closing operation and MOER, the inside attendant pulls the door handle, to open the door. With a fully automated operation, the operator simply steps into the presence sensor and the movable window panel will slide open. When the operator steps out of the presence sensor, the movable window panel will automatically close (same for the MOER, however the magnet will release the door and will self-close). The range for the presence sensor is adjustable to specific customer needs.
- **Security Transaction Drawer.**
Security Transaction Drawer: The stainless steel transaction drawer allows for the secure transfer of goods and currency without the risk of personal contact. A large 18- 5/16"W x 9-1/2"H x 14-9/32" Deep transfer area is large enough for a case of soft drinks while the money clip and change cup allow for the convenient handling of money. The drawer automatically locks when closed and has a manual latch lock to prevent break-ins when the facility is closed. Features level-3 bullet resistance protection
- **Speaker System.**
The pre-wired speaker system provides clear communication with customers without the need for face-to-face contact.
- **Quality Construction**
Anodized aluminum extrusions, stainless steel and a selection of glass options combine to give you an attractive secure window that not only enhances building exteriors, but will not rust, pit or weather.
- **Finish**
This unit is currently available in a clear or bronze anodized aluminum finish or can be powder coat painted in a rainbow of color choices.

- **Fully Assembled, Ready to Install**
Ready Access windows are shipped completely pre-assembled, and fully glazed for lower installation costs. Normal installation takes less than two hours.
- **Warranty and Service Support**
Your Ready Access window comes with a one year limited warranty on parts and labor provided by a worldwide service organization.

STANDARD OPTIONS.

- 2 standard window dimensions with 3 glass types are available: (See Chart on Page # 9)
- An inside stainless steel shelf is also available.

GLASS OPTIONS.

Model 601

- Insulated Glazing: Offers thermo pane protection.
- **Miami- Dade County NOA #16-0307.07 (NON- Impact)**
- Impact Resistant Glazing: Offers protection against "smash & grab" theft and forced entry
- **Miami- Dade County NOA #16-0307.06 (Impact-Hurricane Rated)**
- Level 1 Bullet Resistant Glazing: Offers protection against "smash & grab" theft, forced entry, and gunshots. Glazing is recognized by Underwriters Laboratories as providing Level 1 (9mm) handgun protection per UL Standard 752.

Model 603

- Level 3 Bullet Resistant Glazing: Ideal for high-risk businesses and locations. Protects against break-ins and attacks. Glazing is recognized by Underwriters Laboratories as providing Level 3 (.44 Magnum) handgun protection per UL Standard 752.

Note: Other glazing options available.

Model 602 / 604

- **The Model 602 has a moveable Service Panel.**
This offers the option of servicing customers personally. The service panel self latches each time it closes and features a deadbolt lock and night security bar for complete security during closed hours.
- **The Model 604 has a Stationary Panel.**
In high-risk areas the fixed glass allows for ample visibility without the risk of face-to-face contact.
- **Manual or Electric Operations.**
The Model 602 Single Door Slider helps to keep building costs down by offering the window in a manual operating style. Or for those who experience heavier traffic, an electric operating style is also available. The self closing, MOER and electric models meet health department requirements for self-closing units.
- **Ease of Operation**
In a manual/self closing operation and MOER, the inside attendant pulls the door handle, to open the door. With a fully automated operation, the operator simply steps into the presence sensor and the movable window panel will slide open. When the operator steps out of the presence sensor, the movable window panel will automatically close (same for the MOER, however the magnet will release the door and will self-close). The range for the presence sensor is adjustable to specific customer needs.
- **Security Transaction Drawer.**
Security Transaction Drawer: The stainless steel transaction drawer allows for the secure transfer of goods and currency without the risk of personal contact. A large 18- 5/16"W x 9-1/2"H x 14-9/32" Deep transfer area is large enough for a case of soft drinks while the money clip and change cup allow for the convenient handling of money. The drawer automatically locks when closed and has a manual latch lock to prevent break-ins when the facility is closed. Features level-3 bullet resistance protection
NOTE: This drawer is Optional for the Model 602 and Standard on the Model 604 Window.
- **Speaker System.**
The pre-wired speaker system provides clear communication with customers without the need for face-to-face contact.
NOTE: The speaker system is Optional for the Model 602 and Standard on the Model 604 Window.
- **Quality Construction**
Anodized aluminum extrusions, stainless steel and a selection of glass options combine to give you an attractive secure window that not only enhances building exteriors, but will not rust, pit or weather.
- **Finish**
This unit is currently available in a clear or bronze anodized aluminum finish or can be powder coat painted in a rainbow of color choices.

- **Fully Assembled, Ready to Install**
Ready Access windows are shipped completely pre-assembled, and fully glazed for lower installation costs. Normal installation takes less than two hours.
- **Warranty and Service Support**
Your Ready Access window comes with a one year limited warranty on parts and labor provided by a worldwide service organization.

STANDARD OPTIONS.

- 2 standard window dimensions with 3 glass types are available: (See Chart on Page # 9)
- An inside stainless steel shelf is also available.

GLASS OPTIONS.

Model 602

- Insulated Glazing: Offers thermo pane protection.
- ***Miami- Dade County NOA #16-0307.07 (NON-Impact)***
- Impact Resistant Glazing: Offers protection against "smash & grab" theft and forced entry.
- ***Miami- Dade County NOA #16-0307.06 (Impact-Hurricane Rated)***
- Level 1 Bullet Resistant Glazing: Offers protection against "smash & grab" theft, forced entry, and gunshots. Glazing is recognized by Underwriters Laboratories as providing Level 1 (9mm) handgun protection per UL Standard 752.

Model 604

- Level 3 Bullet Resistant Glazing: Ideal for high-risk businesses and locations. Protects against break-ins and attacks. Glazing is recognized by Underwriters Laboratories as providing Level 3 (.44 Magnum) handgun protection per UL Standard 752.

Note: Other glazing options available.

SPECIFICATIONS AND PERFORMANCE

MODEL 600

Model Number	Unit Voltage		Actual Unit Amps	Dimensions In Inches W X H x D	Weight In Shipping Carton
	USA	International			
Model 600	110/120 VAC 60Hz	220/240 VAC 60Hz	15 A (US) 8 A (Int'l)	47½ x 43½ x 4½	150 to 450 lbs Glass dependant
Model 600	110/120 VAC 60Hz	220/240 VAC 60Hz	15 A (US) 8 A (Int'l)	47½ x 35¾ x 4½	150 to 450 lbs Glass dependant
601/603	110/120 VAC 60Hz	220/240 VAC 60Hz	15 A (US) 8 A (Int'l)	47½ x 43½ x 4½	280 to 310 lbs Glass dependant
601/603	110/120 VAC 60Hz	220/240 VAC 60Hz	15 A (US) 8 A (Int'l)	47½ x 35¾ x 4½	280 to 310 lbs Glass dependant
602/604	110/120 VAC 60Hz	220/240 VAC 60Hz	15 A (US) 8 A (Int'l)	47½ x 43½ x 17	300 to 410 lbs Glass dependant
602/604	110/120 VAC 60Hz	220/240 VAC 60Hz	15 A (US) 8 A (Int'l)	47½ x 35¾ x 17	300 to 410 lbs Glass dependant

Glass Options

Model 600	Thermo Pane	Smash and Grab	Level 1 Glazing	
Model 601	Thermo Pane	Smash and Grab	Level 1 Glazing	
Model 602	Thermo Pane	Smash and Grab	Level 1 Glazing	
Model 603	Thermo Pane	Smash and Grab	Level 1 Glazing	Level 3 Glazing
Model 604	Thermo Pane	Smash and Grab	Level 1 Glazing	Level 3 Glazing

Dimensions

Model 600

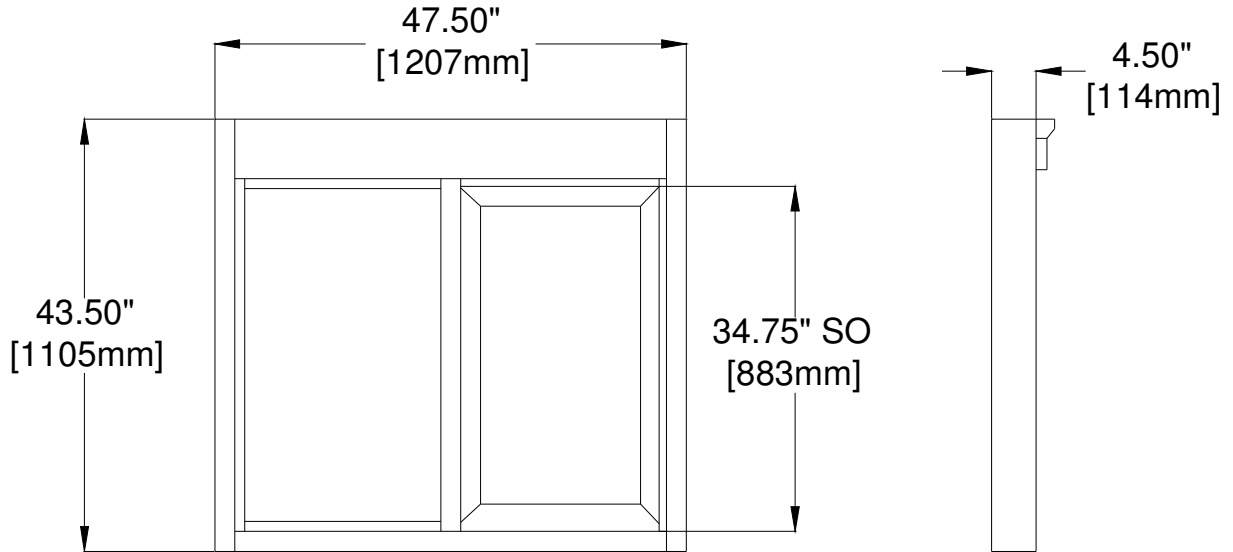

MODEL 600

See Chart for Opening Sizes

Dimensions In Inches W x H x D	Service Opening Size W x H	Glazing Rough Opening Size W x H	Masonry Rough Opening Size W x H
47½ x 43½ x 4½	20" x 35"	47 ¾" x 43 ¾" 1213mm x 1111mm	48" x 44" 1219mm x 1118mm
47½ x 35¾ x 4½	20" x 27 ¼"	47 ¾" x 36" 1213mm x 914mm	48" x 36 ¼" 1219mm x 921mm

MODEL 601 / 603

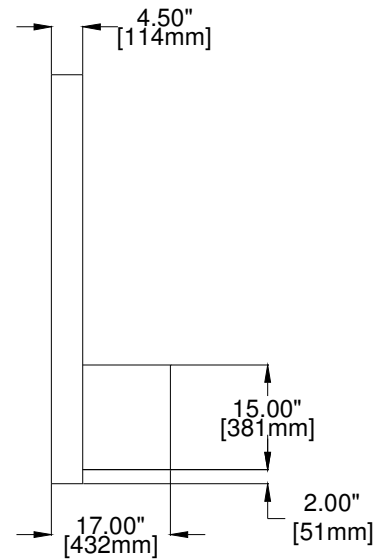
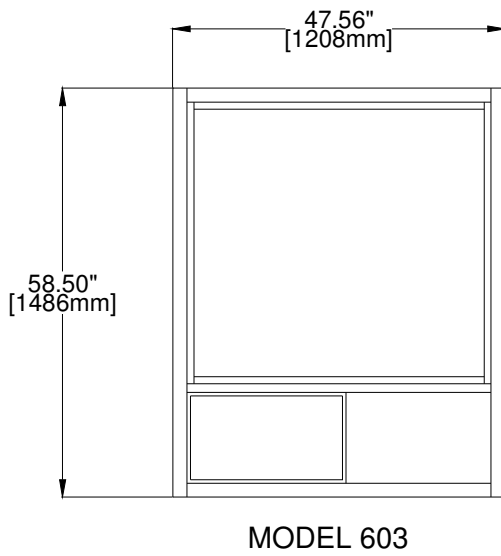
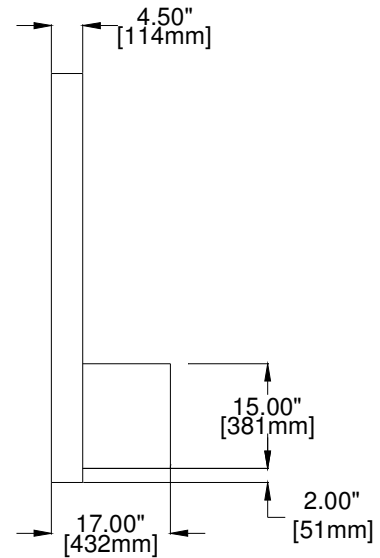
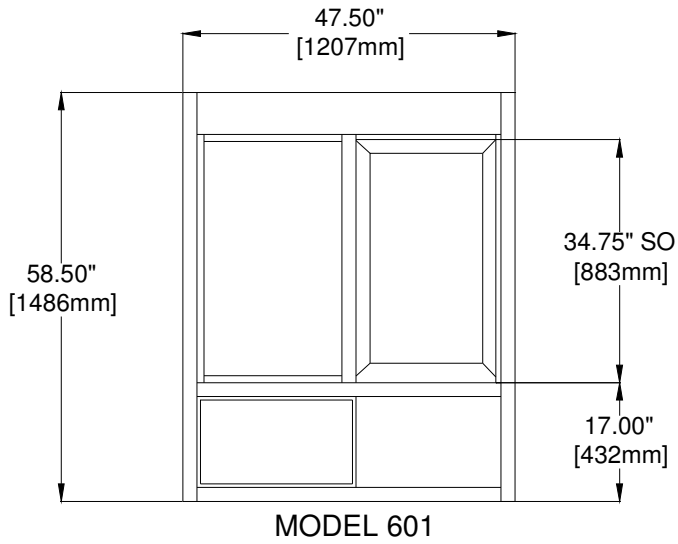

Dimensions In Inches W x H x D	Height Including Drawer	Service Opening Size W x H	Glazing Rough Opening Size W x H	Masonry Rough Opening Size W x H
47½ x 43½ x 4½	58 ½" H	20" x 34 ¾"	47 ¾" x 58 ¾" 1213mm x 1492mm	48" x 59" 1219mm x 1499mm
47½ x 35¾ x 4½	50 ¾" H	20" x 27"	47 ¾" x 51" 1213mm x 1295mm	48" x 51 ¼" 1219mm x 1302mm

*** Model 601 available in a service opening size that passes the California restricted opening requirements.**

MODEL 602 / 604

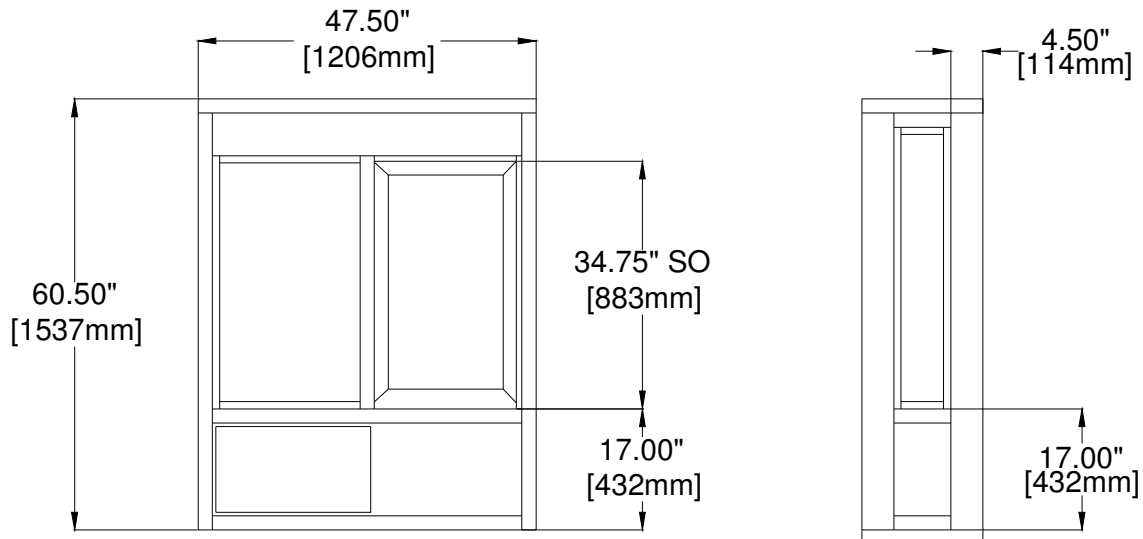

MODEL 602

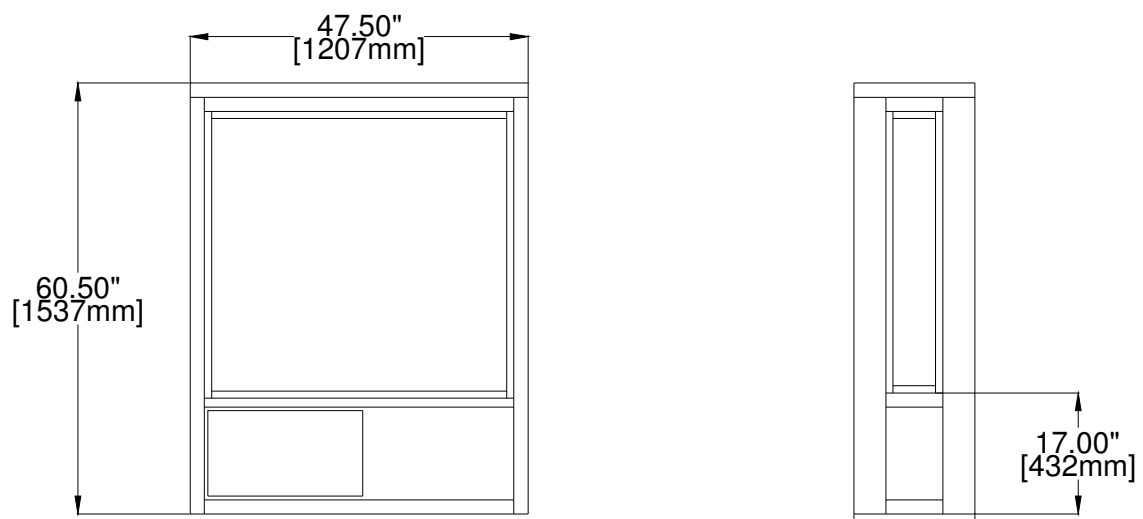

MODEL 604

Dimensions In Inches W x H x D	Height Including Drawer	Service Opening Size W x H	Glazing Rough Opening Size W x H	Masonry Rough Opening Size W x H
47½ x 43½ x 17	60 ½" H	20" x 34 ¾"	47 ¾" x 60 ¾" 1213mm x 1543mm	48" x 61" 1219mm x 1549mm
47½ x 35¾ x 17	52 ¾" H	20" x 27"	47 ¾" x 53" 1213mm x 1346mm	48" x 53 ¼" 1219mm x 1353mm

*** Model 602 available in a service opening size that passes the California restricted opening requirements.**

Safety Information

WARNING: To avoid the risk of fire, Electric Shock or injury to persons, observe the following:

1. Before servicing or cleaning the unit, switch the power off at the mechanical switch near the unit (Installed by an Electrician) or the electrical entry service panel/circuit breaker. (Load Center)
 - **OSHA LOCK OUT – TAG OUT** procedures are to be observed to prevent power from being switched on accidentally.
2. Any Installation and / or Electrical work must be done by **QUALIFIED** persons in accordance with all applicable codes / standards and manufacturers recommendations and specifications.
3. **DO NOT** insert fingers and / or foreign objects into the Drive-Thru Window.
DO NOT block or tamper with the unit in any manner while it is in operation.
4. This product must not be used in Potentially Dangerous locations such as Flammable, Explosive Chemical – laden environment.

Installation Procedures

Tools required to perform the installation

- Electric Drill
- Metal Drill bits –
 - 1/8" (3mm)
 - 1/4" (6mm)
 - 1/2" (13mm)
 - 1" (25mm)
- Screwdrivers – Slotted and Phillips
- Hacksaw
- Jack / Utility Knife
- Flat File – Coarse
- Caulking gun
- 1/4" Nut Driver
- Extension Cord
- Masonry drill bit –
 - 1/4" (6mm)
 - 1" (25mm)
 - 1 1/2" (38mm)
- Masonry Hole Saw – 1" (25mm)
- Channel Lock Pliers
- Tape Measurer
- Wire Cutter
- Step Ladder
- Level

Materials required for installation

- Window framing, architect specified and installed in building.
(Ready Access recommended material is 1/8" (3mm) x 1 3/4" (44.5mm) x 4" (102mm) hollow aluminum tubing or glazing channel)
- Electrical Tape
- Wire Nuts
- Caulking – silicone (Color specific to the color of window)
- Connectors for conduit as required
- Shingle type shims – as required to level and plum the window

Physical Installation

Model 600

Before you begin installing your Ready Access Drive-Thru Window, you must determine what type of installation will be required. Example: Wood Framing, Masonry Framing, etc.

See Chart on page 10 for Masonry and Glazing Rough Opening Sizes

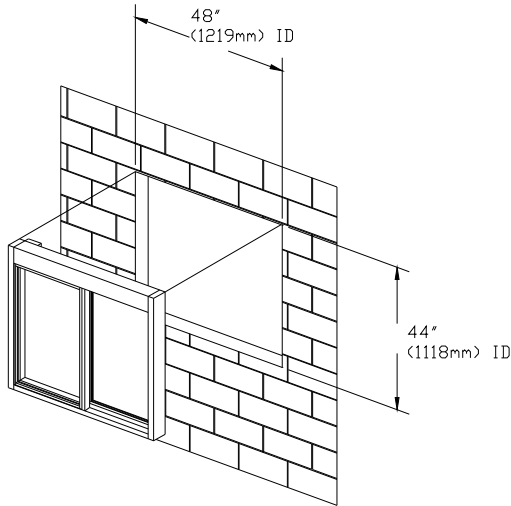

MASONRY WALL
ROUGH OPENING

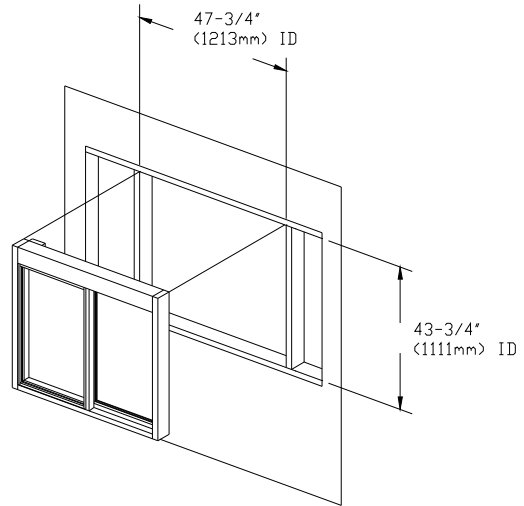

GLASS STORE FRONT
DAYLIGHT OPENING

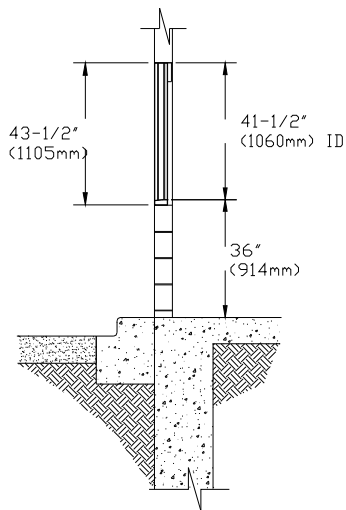

SECTION THROUGH
THE MASONRY WALL

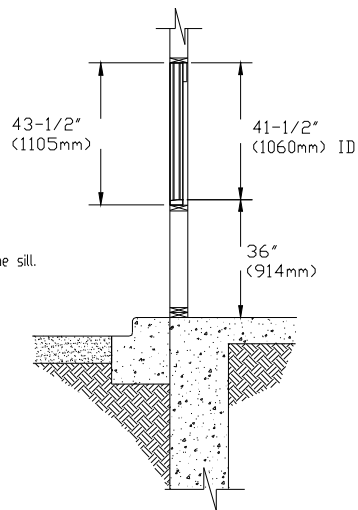

SECTION THROUGH THE
GLASS STORE FRONT

* Minimum Distance from
the floor to the top of the sill.

MODEL 602 / 604

Before you begin installing your Ready Access Drive-Thru Window, you must determine what type of installation will be required. Example: Wood Framing, Masonry Framing, etc.

See Chart on page 12 for Masonry and Glazing Rough Opening Sizes

The window must be installed square and plumb.

Installation illustrations are for reference only. Construction and local codes will determine the proper installation of the window.

Contact Ready Access for more information.

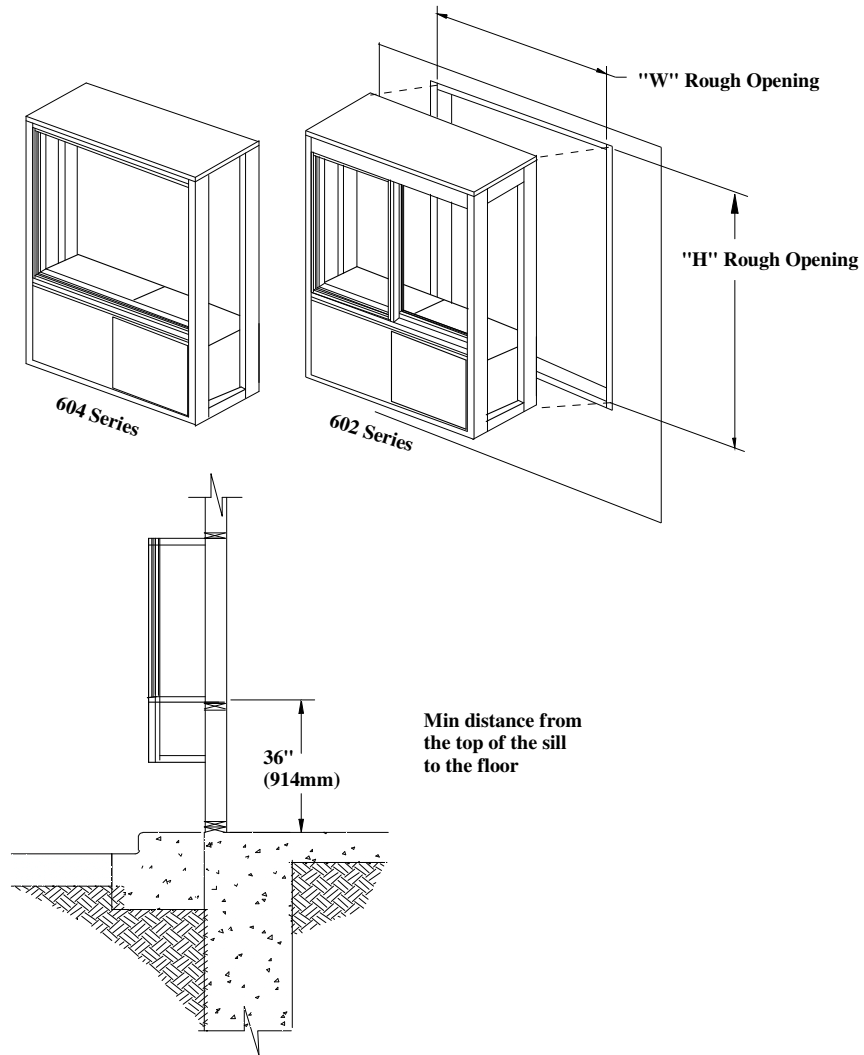

MODEL 601 / 603

Before you begin installing your Ready Access Drive-Thru Window, you must determine what type of installation will be required. Example: Wood Framing, Masonry Framing, etc.

See Chart on page 11 for Masonry and Glazing Rough Opening Sizes

The window must be installed square and plumb.

Installation illustrations are for reference only. Construction and local codes will determine the proper installation of the window.

Contact Ready Access for more information.

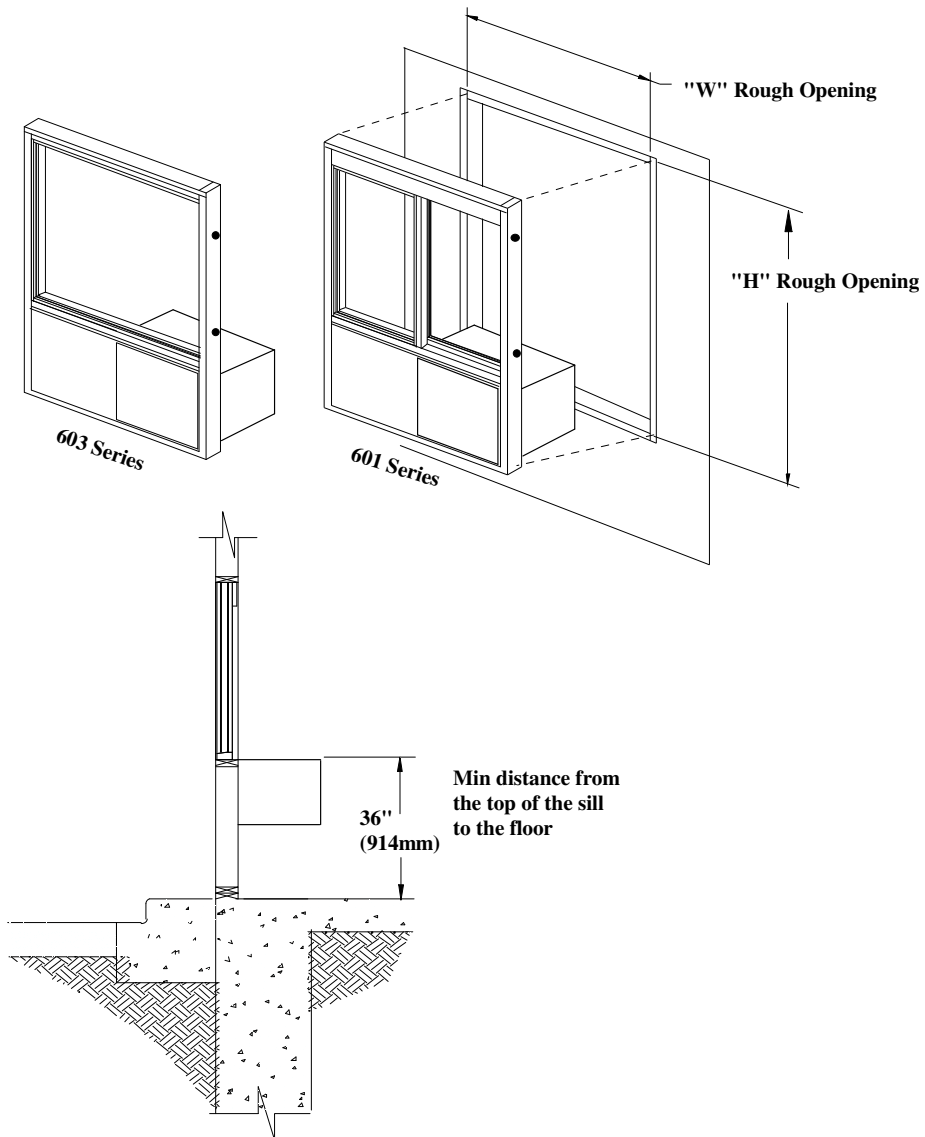

**WARNING:
TWO PEOPLE ARE REQUIRED FOR THE LIFTING AND
INSTALLATION OF THE WINDOW.**

1. Confirm that the customer-supplied frame is made to accommodate the dimensions.
2. Confirm that AC power has been run and is ready for connection to the window.
3. Check shipping carton for any shipping damage and remove window from the carton.
4. Check window for any shipping damage.

NOTE: There are two wall-mounting applications. The mounting space can be surrounded either by sidelights (windows) or masonry. In both cases the upper part of the window above the counter top (window sill) fits flush with the outside of the wall. The illustrations will show the walls with the sidelights, as this is the most common application. (Figure 3 and 4)

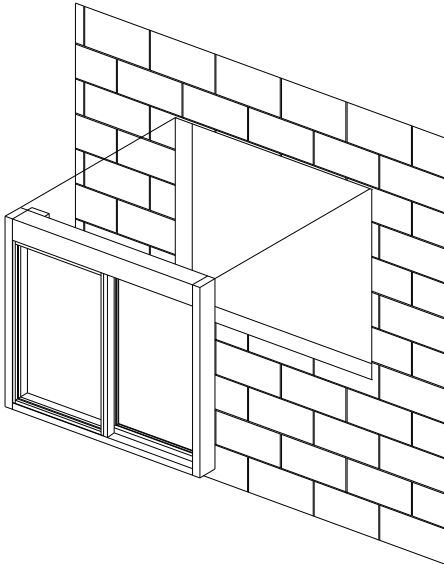

Figure 3

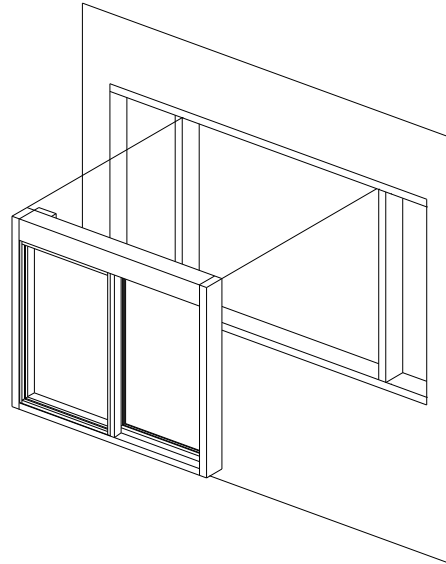

Figure 4

NOTE: If mounting the window in a masonry wall the window mounts flush with the outside finishing of the building. Drill points are scribed directly into the masonry. The outside edge of the mullion should be flush with the outside finishing of the building. (See Figure 3 and 4)

5. Position the window and place it into the customer-supplied frame. As shown in Figure 3 and 4
6. With one person holding the window in place, level the window using the shim shingles as needed.

- Using the window mounting holes as a template, drill a quantity of 4 – 3/16" (5mm) diameter holes for mounting. (See Figure 5)

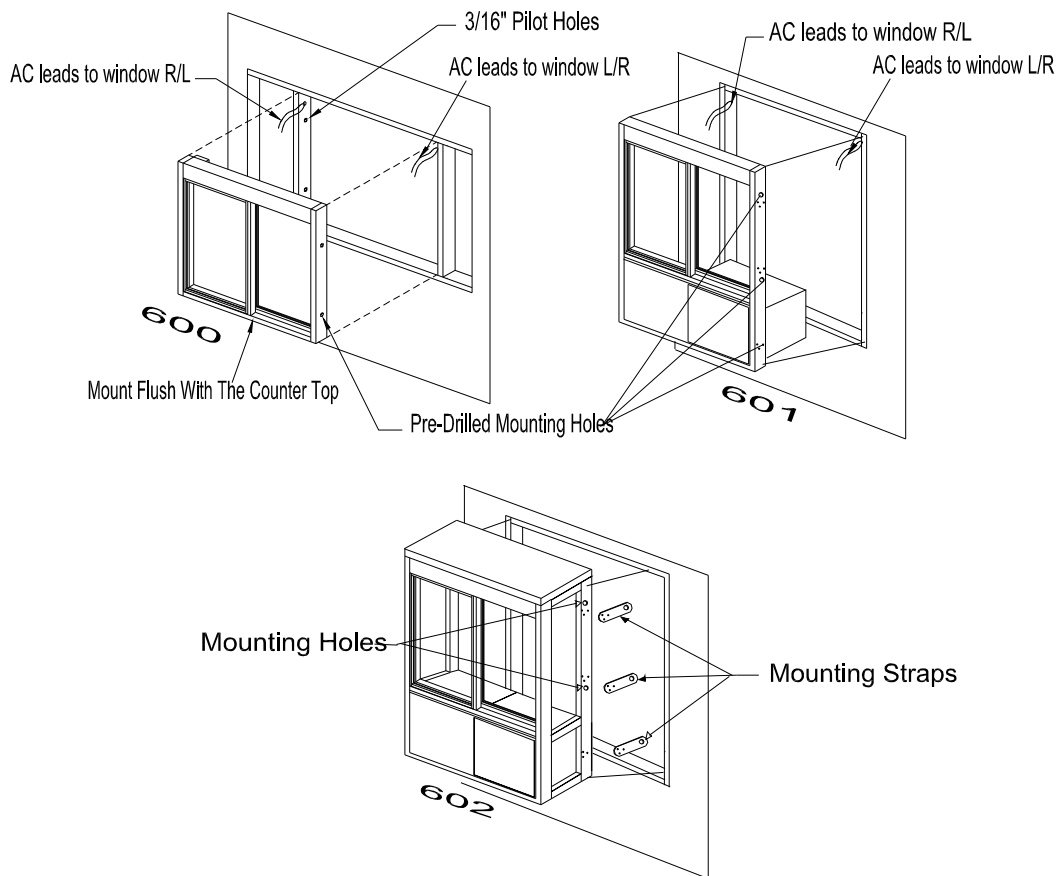

Figure 5

- Take the window back out and drill the mounting holes. Set the anchors as needed.
- With one person holding the window in place from the outside, set the mounting screws.
- When the window is fully secured, seal the outside of the window to the frame or building using silicone caulk.

Electrical Installation – 10/2003 Chassis Style

All power must be connected and wired by a qualified electrician and must be in compliance with all state and local codes.

The incoming AC power line must be connected to the wires in the duplex box located in the top header (Per Standard electrical code.) The green “grounding” wire is to be attached to the frame of the unit.

WARNING: Use only 110/120VAC – 60Hz source with a dedicated 15Amp circuit.

International power: 220/240VAC – 50/60Hz with a dedicated 8amp branch circuit.

WARNING: This must be a dedicated circuit. Other electrical equipment must not share the same line from the 15Amp circuit breaker.

WARNING: Turning off the front panel rocker switches does not remove the 110/120 volts of electrical power from the unit

WARNING: To disconnect the power completely from this unit, turn OFF the mechanical switch near the unit (Installed by an Electrician) or the electrical entry service panel/circuit breaker panel (Load Center) for this unit.

- OSHA LOCK OUT – TAG OUT procedures are to be observed to prevent power from being switched on accidentally.

1. Remove the 2 screws holding on the AC access panel. **Do not remove the slide channel cover.**
2. Electrician to drill hole in unit as shown. Install connector before running power line to unit.

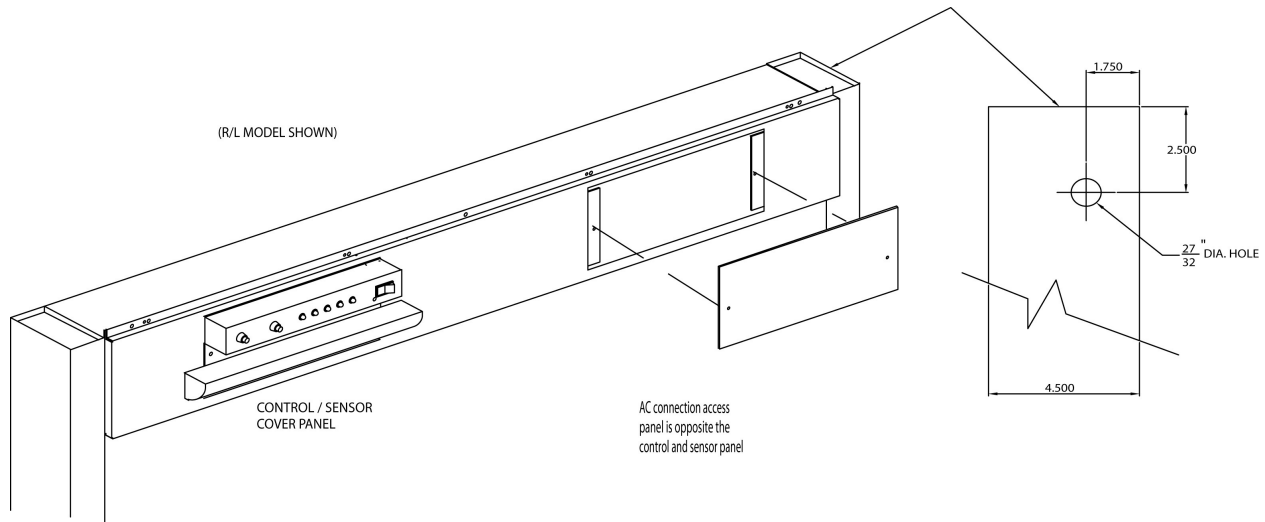

3. Wire the AC source line to the Terminal Block located in the header of the window.

AC Terminal Block

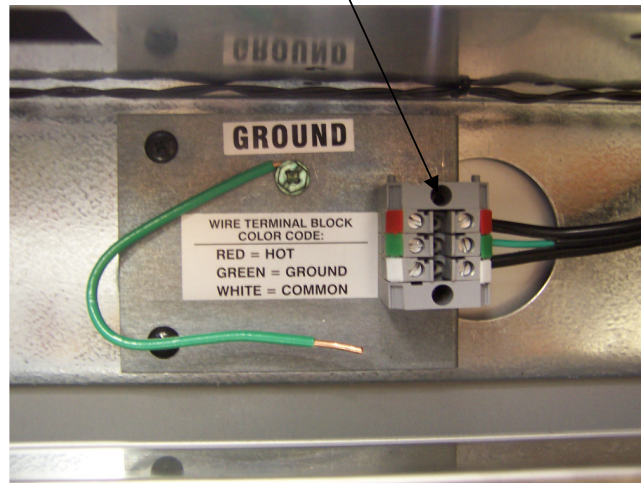

NOTE: TO GROUND UNIT USE PIGTAIL BY TERMINAL BLOCK. THE LINE (L1) IS INDICATED BY THE (RED) TAB AND THE RETURN (NEUTRAL) IS INDICATED BY THE (WHITE) TAB. ON THE TERMINAL BLOCK FOR PIGTAIL LEADS COMING INTO TERMINAL BLOCK, WIRE TIES PROVIDED TO SECURE FREE END OF THE WIRE LEADS TO PREVENT WIRES COMING IN CONTACT WITH MOVING PARTS. NOTE: USE COPPER CONDUCTORS ONLY.

4. Turn "ON" the power to the unit. (Load center circuit breaker and power switch on the "Control Panel").
5. Test window operations. See "Testing Procedures".

Initial Window Operation Testing Procedures

Action	Reaction
Turn the power “ OFF ” at the rocker switch located on the controller unit. Manually open and close the door several times.	When the door is opening, the “MOTOR RUN” lamp will illuminate green. When the door is closing, “MOTOR RUN” lamp will illuminate red. The “POWER” lamp must illuminate during both operations. If neither of these lamps illuminate during any of the processes, proceed to the “Troubleshooting” section.
Turn the power “ ON ” at the rocker switch located on the controller unit. Break the electric eye beam to open the door.	The door will open.
With the power “ ON ” break the electric eye beam momentarily to open and close the door.	The door will open. They will remain in the open position for either approximately 3.0 or 6.0 seconds before closing (Default Settings)
With the power “ ON ” press the “CLOSE DELAY” button located on the controller unit once and break the electric eye beam to open the door	The door will open and the length of time that the door remains open will toggle between 3.0 and 6.0 seconds before closing. (Default Settings)
With the power “ ON ” break the electric eye beam momentarily to open and close the door. Insert an object at least 4” (101.6mm) wide between the door and the frame as the door closes.	The door will automatically reverse their action (the door will open), when an object is caught between or restricting the closing of the door.

SETUP SENSOR

1. REMOVE TWO SCREWS OFF THE SENSOR COVER.
2. REMOVE THE ADJUSTING TOOL SEE FIGURE "A".
3. INSERT THE ADJUSTING TOOL INTO THE HALF INCH SLOT SEE FIGURE "B".
4. AFTER YOU INSERT THE TOOL PULL THE TOOL TOWARDS YOU JUST ONE CLICK. IF DOOR TRIES TO CLOSE AND RE OPENS, PULL TOWARDS YOU ONE MORE CLICK. CONTINUE UNTIL DOOR CLOSES SEE FIGURE "B".
5. INSTALL THE COVER AFTER FINISH THE SETUP.

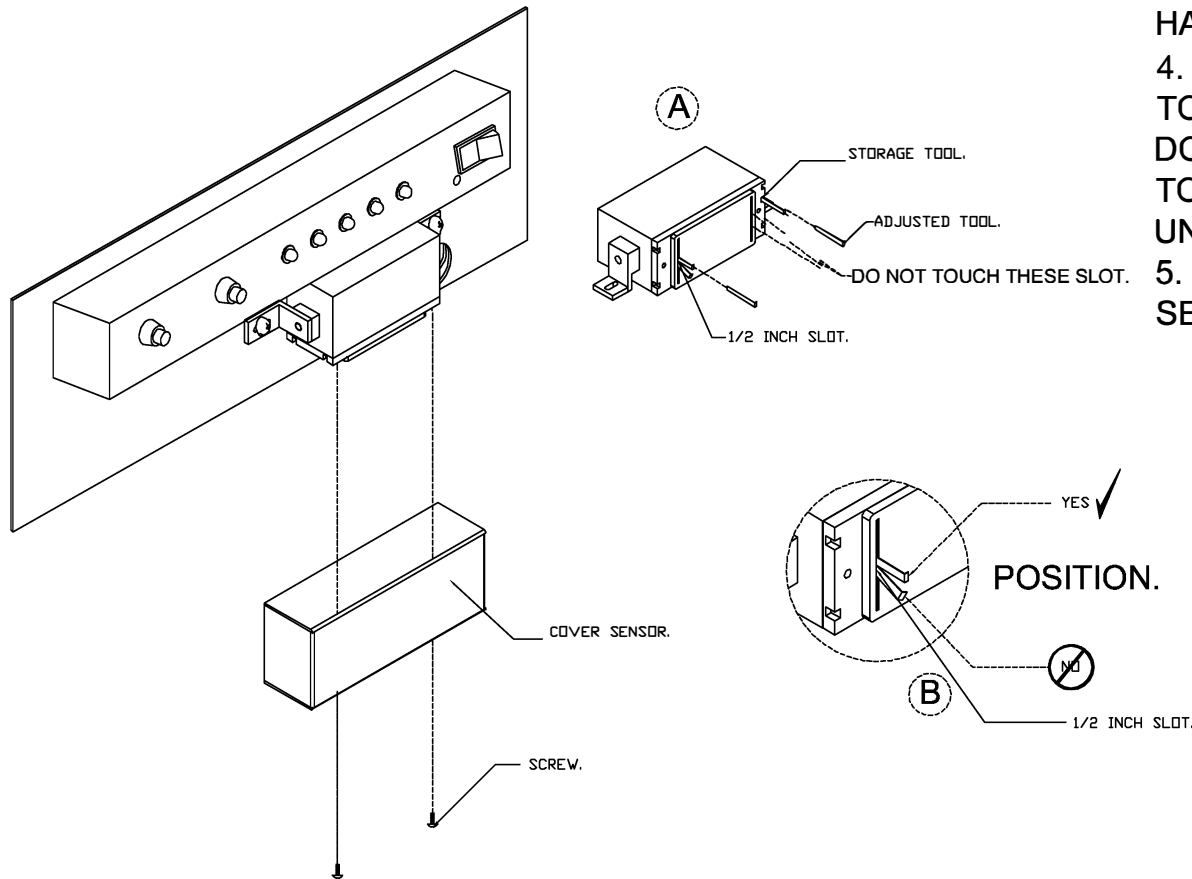

Door Alignment

Adjustments to the door height and alignment are accomplished by turning one or both of the eccentric nuts located at the top of the doorframe where it mounts to the slide track. (Figure 7)

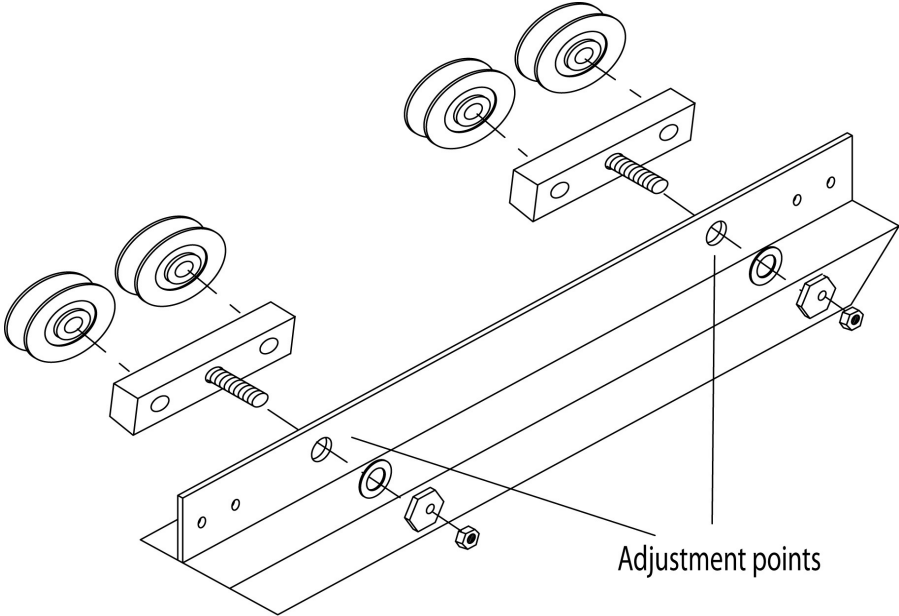

600 Series Upper Door Channel

Figure 7



Adjusting Nuts

CLOSE DELAY TIMER INFORMATION

The close delay timer is used to adjust the amount of time that the door will stay open after stepping out of the sensor range. The factory preset is 3 seconds. The range of setting is from 0 to 45 seconds. If the close delay button is activated on the control panel, this time will be doubled. Example: Timer setting is 5 seconds, press close delay button and the new time is 10 seconds. Press the close delay button again and the time is restored back to 5 seconds. The following diagrams are examples of timer settings:

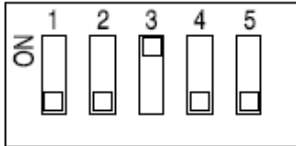

Equals 3 second delay

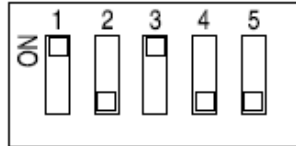

Equals 13 second delay

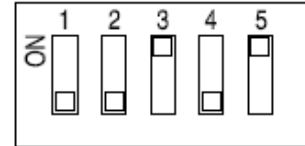

Equals 35 second delay

THE FOLLOWING WIRING DIAGRAMS ARE FOR REFERENCE FOR THE DIFFERENT MODELS OF READY ACCESS PASS THRU WINDOWS.

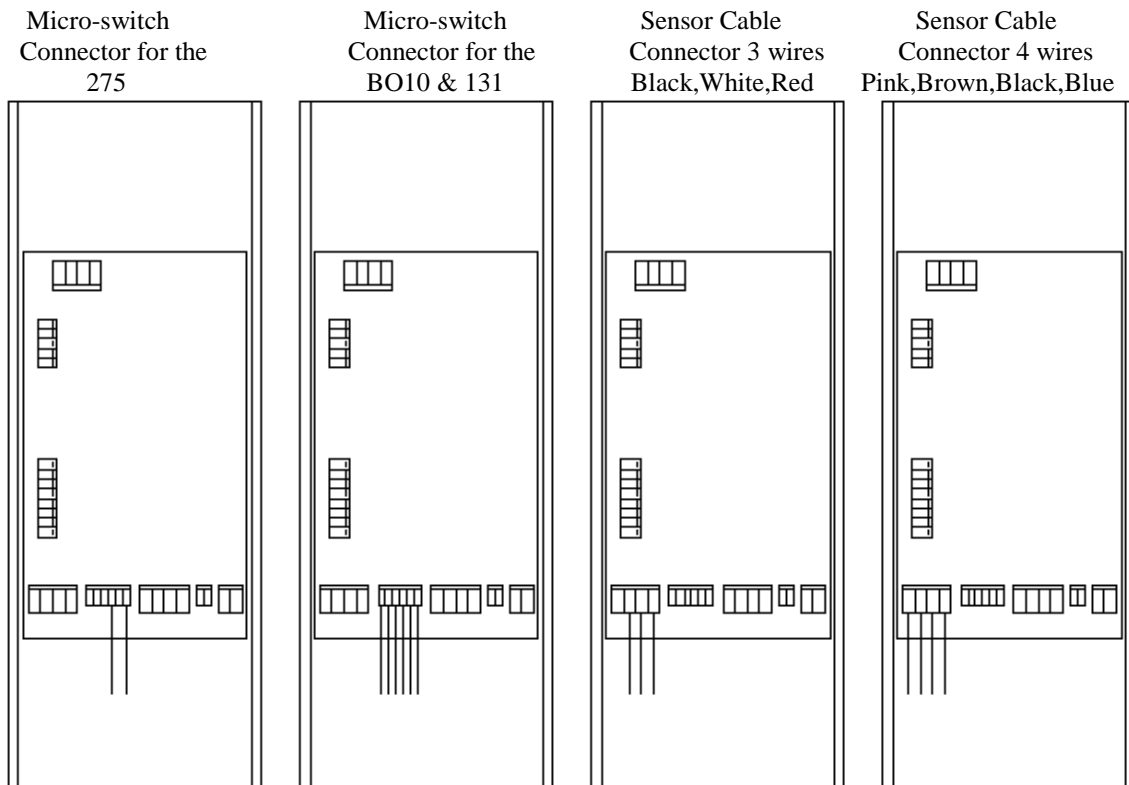

3 Wire Instruction:

Connect wires for eye to wires on eye cable

<u>Eye</u>	<u>Eye Cable</u>
Brown	Black
Black	White
Pink/Blue	Red

Operation Procedures

Modes of Operation:

The Model 600 Single Door Slider window has four modes of operation, Manual/Self Closing, MOER and Automatic.

After installation of the Model 600 Manual or Electric Sliding window, completion of the testing procedures and the installation of the decorative covers, the window is ready for normal use.

The **Manual Mode:** The opening and closing of the window is done by hand.
(DO NOT OPEN OR CLOSE THE DOOR WITH ANY UNDUE FORCE)

Manual Operations:

1. Unlock the deadbolt and thumb-turn on the door, drop the lock bar to the open position.
2. Release the manual latch and push the door open.
3. Push the door closed and allow the manual latch reset. On the self closing unit, let go of the door and it will self-close.
4. Relock the deadbolt and thumb-turn.

MOER (Manual Open/Electronic Release)

1. Unlock the deadbolt and thumb-turn on the door, drop the lock bar to the open position.
2. Release the manual latch and push the door open, all the way back until the magnet sets.
3. Walk out of the sensor beam and the door will release from the magnet and it will self-close.
4. Relock the deadbolt, thumb-turn and security lock bar.

The **Automatic Mode** is reached by turning "ON" the main power to the window. Stepping in and out of the sensor's range opens and closes the door.

Automatic Operations: Serial # 103800 and Before

1. On the controller unit, turn the power rocker switch to the "ON" position.
2. Check that the red portion of the rocker switch is visible and that the red power lamp is illuminated
3. Break the electronic eye beam or step into the sensor beam path. The red beam break and green motor run lamps go on.
4. Step out of the beam path and wait 3 to 6 seconds for the door to close. The red motor run lamp and red close detect lamps will illuminate. After the door close note that the red power lamp and the current detect lamps are "ON".
5. If the door does not operate correctly, go to the troubleshooting guide in this manual. If the door still do not operate properly, then call Ready Access at

1-800-621-5045

6. The door can be operated manually by pulling the manual release located at the top of the door.

NOTE: Turn the power off to the window to prevent any damage to the PCB.

Automatic Operations: Serial # 103801 to Present

1. Hook up power.
2. Turn power on. Window is ready for normal operation.
3. Test and check all operation of the door.
4. Observe operation of window unit being operated by store personnel before leaving.

Each operator must read the operations manual before operating the unit.

Controls Identification, Explanation and Function



Controller Unit

Lamps and Switches	Function
Power Lamp	This lamp indicates that the power rocker switch is on and the controller is receiving power.
Motor Run Lamp	<p>The “MOTOR RUN” lamp indicates that power is being applied to the motor. When the door is opening, lamp will illuminate green. When the door is closing, the lamp will illuminate red.</p> <p>The lamp also allows for the diagnostic checking of the motor and motor wiring. To test, turn the power “OFF” at the rocker switch and manually open and close the door. This will cause the lamp to illuminate either green or red. The “POWER” lamp must illuminate during both operations. If neither of these lamps illuminate during any of the processes, proceed to the “Troubleshooting” section.</p>
Beam Break Lamp	This lamp indicates that the electric eye beam or presence sensor beam has been broken and/or the “CLOSE DELAY” timer is still timing out.
Close Detect Lamp	This lamp is red and indicates that a “CLOSE” sequence has been initiated. It will always light during a door closure and will go out just before the door contacts the frame. When the lamp is out, the automatic reverse feature is disabled.
Current Detect Lamp	This lamp is red and indicates an overload has been detected. This lamp may light on opening but is automatically disabled. The lamp will come on when the door is fully closed or when an obstruction has been encountered
Beam Test Switch	<p>Pressing the “BEAM TEST” button once will test the operations of the door without using the electric eye or presence sensor. To test, the operator should not be in the path of the light beam or presence sensor.</p> <p>Standing in the light beam while pressing the button will put the window into a test mode. This will make the window continuously operate (open and close) automatically. You must turn the power off and back on to reset the window.</p>
Close Delay Switch	Pressing this button will toggle the length of time that the door remains open between 1.5 and 3.0 seconds before closing.

Maintenance

Maintenance Schedule

Scheduled maintenance should be performed on a regular basis. This is to assure proper operation and performance of the Model 600 windows.

Daily

Check the sill and drawer for foreign materials and/or syrup. (Anything that might cause the window to bind up and not operate smoothly.)

Use warm soapy water or carbonated water to clean the window.

Monthly

Follow safety procedures before opening the unit.

Check the interior of the unit for any build up of any foreign materials using a dry cloth.

NOTE: KEEP ANY LIQUIDS OFF THE INTERIOR COMPONENTS.

Clean moving parts and lubricate with silicone or Teflon spray.

NOTE: Do NOT use Grease or Oils. Do NOT lubricate the motor clutch assembly.

Yearly

Have a service technician come in and perform a maintenance check on the unit.

SERVICE

Troubleshooting Guide

Issue	Probable Cause	Resolution
<p>Power switch in the "ON" position but the light is not illuminated.</p>	<ul style="list-style-type: none"> • No power to the controller unit <ul style="list-style-type: none"> ➢ Main Circuit breaker is defective or not "ON" ➢ The fuse on the power supply is blown ➢ Main power rocker switch is defective ➢ AC wiring is defective 	<ul style="list-style-type: none"> ➢ Reset or replace the main circuit breaker in the load center ➢ Replace the fuse on the power supply ➢ Test rocker switch with an ohmmeter. Replace if necessary ➢ Check AC wiring for opens. Replace if necessary
	<ul style="list-style-type: none"> • Red Lamp/s not illuminating 	<ul style="list-style-type: none"> • Replace the PCB assembly cover
	<ul style="list-style-type: none"> • The 4 pin power connector to the main PCB assembly is not secure 	<ul style="list-style-type: none"> • Secure the connector/s to the power supply
	<ul style="list-style-type: none"> • The connector/s to the rocker switch are not secure 	<ul style="list-style-type: none"> • Secure the connector/s to the rocker switch
<p>"BEAM BREAK" lamp is "OFF" and does not illuminate when the electric eye is broken.</p>	<ul style="list-style-type: none"> • Defective electric eye assembly <ul style="list-style-type: none"> ➢ Pressing the "BEAM TEST" button on the controller unit can test this. The door should open, pause and close. If the door operate normally, check other causes listed below 	<ul style="list-style-type: none"> • Replace the electric eye assembly
	<ul style="list-style-type: none"> • Loose electric eye cable from the PCB 	<ul style="list-style-type: none"> • Secure the cable connector (3 or 4 pin)
	<ul style="list-style-type: none"> • Loose or broken wire/s in the electric eye cable 	<ul style="list-style-type: none"> • Check that the electric eye cables are secure and not broken
	<ul style="list-style-type: none"> • Defective lamp 	<ul style="list-style-type: none"> • Replace the PCB assembly cover
	<ul style="list-style-type: none"> • Defective PCB assembly 	<ul style="list-style-type: none"> • Replace the PCB assembly
<p>The door will not "AUTO REVERSE" for an obstruction when closing and the motor continue to run.</p> <p>The "CURRENT DETECT" lamp will not illuminate.</p>	<ul style="list-style-type: none"> • Loose or broken wires to the limit switches or the PCB assembly 	<ul style="list-style-type: none"> • Secure or replace the cable assembly
	<ul style="list-style-type: none"> • Defective controller unit 	<ul style="list-style-type: none"> • Replace the controller unit

Issue	Probable Cause	Resolution
<p>When the beam is broken, the door does not open. The red "POWER" and "BEAM BREAK" lights and the green "MOTOR RUN" light on the CONTROLLER unit are "ON".</p>	<ul style="list-style-type: none"> • Defective motor assembly <ul style="list-style-type: none"> ➤ To test for a defective motor, open and close the door with the power "OFF". If the motor is faulty, the red/green "MOTOR RUN" lamp will not illuminate 	<ul style="list-style-type: none"> • Replace the motor assembly
	<ul style="list-style-type: none"> • Solenoid latch in the door is stuck or defective <ul style="list-style-type: none"> ➤ To test for a defective solenoid, manually open the door halfway and break the beam. The solenoid should retract the hook and the door should open, pause and close. Break the beam again to verify that the door are not opening ➤ Check the wiring to the solenoid 	<ul style="list-style-type: none"> • Replace the solenoid
	<ul style="list-style-type: none"> • Defective components on the cable drive assembly. ("S" hook, cable, spring, chain, bearing 	<ul style="list-style-type: none"> • Replace the defective component
<p>Beam Break Lamp is "ON" and the door open, but they do not close.</p>	<ul style="list-style-type: none"> • Loose or broken wires 	<ul style="list-style-type: none"> • Secure or Replace the cable assembly
	<ul style="list-style-type: none"> • Defective electric eye assembly <ul style="list-style-type: none"> ➤ Disconnect the cable for the electric eye and press the "BEAM TEST" button. If the door operate properly the eye is defective 	<ul style="list-style-type: none"> • Replace the eye assembly
	<ul style="list-style-type: none"> • Defective PCB assembly <ul style="list-style-type: none"> ➤ Disconnect the cable for the electric eye and press the "BEAM TEST" button. If the door do not operate properly the PCB is defective 	<ul style="list-style-type: none"> • Replace the PCB assembly
<p>The door closes fully but open back up as soon as the door comes in contact with the frame.</p>	<ul style="list-style-type: none"> • Loose or broken wires to the limit switches or the PCB assembly 	<ul style="list-style-type: none"> • Secure or replace the cable assembly
	<ul style="list-style-type: none"> • Limit switch striker is loose or out of alignment 	<ul style="list-style-type: none"> • Tighten and/or align the striker plate
	<ul style="list-style-type: none"> • Defective controller unit 	<ul style="list-style-type: none"> • Replace the controller unit
	<ul style="list-style-type: none"> • Loose Cable and Chain 	<ul style="list-style-type: none"> • Tighten the cable pulley

Issue	Probable Cause	Resolution
The "CLOSE DELAY" switch is not working properly.	<ul style="list-style-type: none"> Loose or broken connection to the PCB Assembly 	<ul style="list-style-type: none"> Secure the cable connector to the PCB assembly or replace the control PCB cover
	<ul style="list-style-type: none"> Defective "CLOSE DELAY" switch 	<ul style="list-style-type: none"> Replace the control PCB cover
Motor continues to run after the door is fully opened.	<ul style="list-style-type: none"> Loose or broken wires to the limit switches or the PCB assembly 	<ul style="list-style-type: none"> Secure or replace the cable assembly
	<ul style="list-style-type: none"> Defective "Open" limit switch 	<ul style="list-style-type: none"> Replace the appropriate switch
	<ul style="list-style-type: none"> Defective controller unit 	<ul style="list-style-type: none"> Replace the controller unit
<p>The door does not fully close and goes into AUTOREVERSE to the fully open position.</p> <p>Door may be sluggish in operations.</p> <p>The "CURRENT DETECT" lamp will be illuminated before the "CLOSE DETECT" lamp goes out. (BEFORE REPLACING THE MOTOR CALL READY ACCESS FOR FURTHER INSTRUCTIONS)</p>	<ul style="list-style-type: none"> Spilled soft drink syrup residue is under the door and on the weather stripping of guide block 	<ul style="list-style-type: none"> Clean the weather stripping, counter and door guides on the bottom of the door with soda water
	<ul style="list-style-type: none"> Door are dragging on the counter top 	<ul style="list-style-type: none"> Adjust the door height and alignment. (Refer to the adjustments section of this manual)
	<ul style="list-style-type: none"> Defective motor assembly <ul style="list-style-type: none"> To test for a defective motor, open and close the door with the power "OFF". If the motor is faulty, the red/green "MOTOR RUN" lamp will not illuminate 	<ul style="list-style-type: none"> Replace the defective motor assembly
	<ul style="list-style-type: none"> Defective CONTROLLER unit 	<ul style="list-style-type: none"> Replace the CONTROLLER unit
<p>The "BEAM TEST" switch is not working properly.</p> <p>The "BEAM BREAK" lamp is not illuminated and the door does not open.</p>	<ul style="list-style-type: none"> Loose or broken connection to the PCB assembly 	<ul style="list-style-type: none"> Secure or replace the cable assembly
	<ul style="list-style-type: none"> Defective CONTROLLER unit 	<ul style="list-style-type: none"> Replace the CONTROLLER unit
	<ul style="list-style-type: none"> Defective PCB assembly 	<ul style="list-style-type: none"> Replace the PCB assembly

Parts Lists

Parts List (Description/Part Number)

Description	Current Part Number	Previous Part Number	Note
Cable & Chain Assy (New Chassis)	85001800	N/A	
Cable, BEA Sensor to PCB (New Chassis)	20112104	N/A	
Door Assembly	Call Manufacturer form part #, price and availability		
Electric Chassis L/R	CALL FOR #	N/A	Provide Serial #
Electric Chassis R/L	CALL FOR #	N/A	Provide Serial #
Handle - Manual Release - 600 L/R	85002420	N/A	New Style 2003 (chassis)
Handle - Manual Release - 600 R/L	85002410	N/A	New Style 2003 (chassis)
Hanging Hardware Kit (Adj. Nut) (2)	85183400	65183401	
Lock - Dead Lock w/ faceplate	20090086	N/A	
Lock - Mortise Thumb-Turn	20090084	N/A	
Power Supply (chassis only)	CALL FOR #	N/A	Provide Serial #
Roller Block Replacement Kit - 2 Pcs	85003200	N/A	
Roller Groove Bearing - KIT	85003600	20010030	Single Roller
Screw for inside cover, sensor striker	10010114	N/A	
Sensor Assy – beam box Brz	85100801	N/A	
Sensor Assy – beam box Clr	85100802	N/A	
Solenoid & Hook Assy for Electric Chassis L/R	85002920	N/A	
Solenoid & Hook Assy for Electric Chassis R/L	85002910	N/A	
Switch - Micro	20110281	N/A	
Universal Control Board	85002001	N/A	

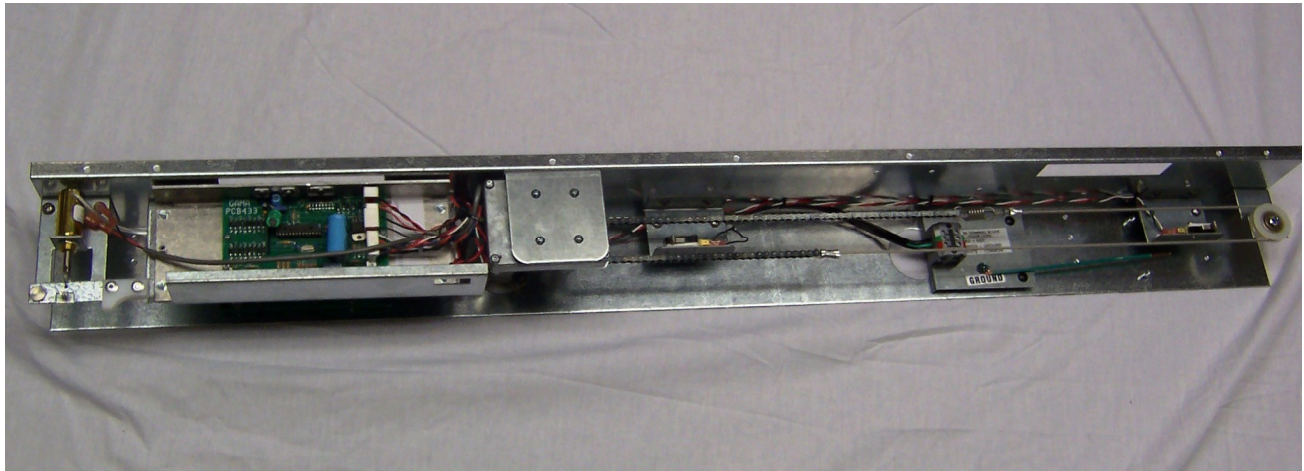

600 SERIES WINDOWS

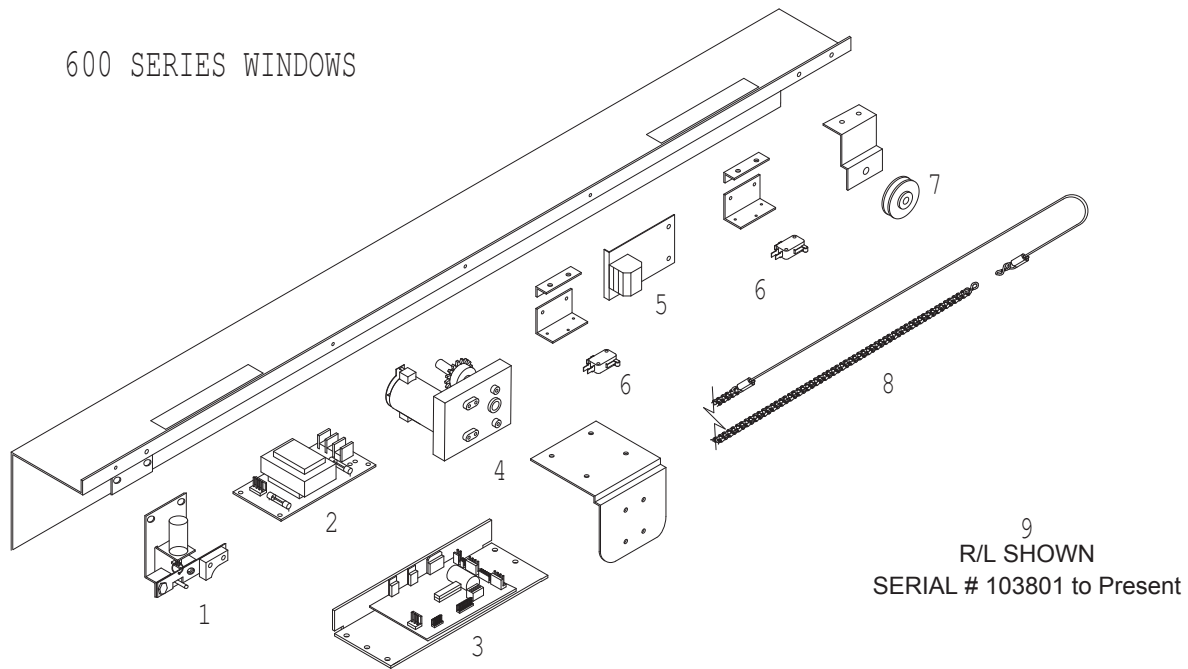

REF ID #	PART NUMBER	DESCRIPTION	REF ID #	PART NUMBER	DESCRIPTION
1	85002910	Solenoid and Hook Assy R/L	5	20220003	AC Terminal Block
1	85002920	Solenoid and Hook Assy L/R	6	20110281	Micro switch
2	Call for #	120V Power Supply	7	20200142	Kilrol Pulley
*2	Call for #	220V Power Supply (Int'l)	8	85001800	Cable and Chain Assy
3	85002001	Universal Control Board	9	Call for #	Electric Chassis – L/R
4	85186700	Motor w/ sprocket Assy	9	Call for #	Electric Chassis – R/L

Note: For serial #'s 103800 and older, only one micro switch is required.

85003200
Roller Block Assembly

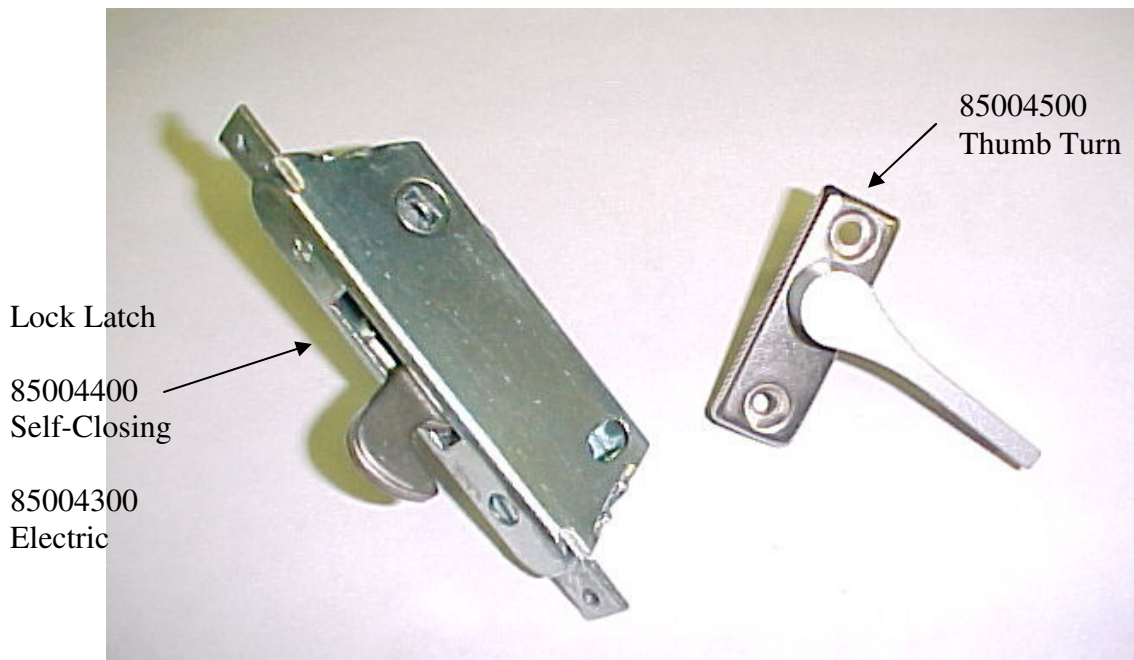
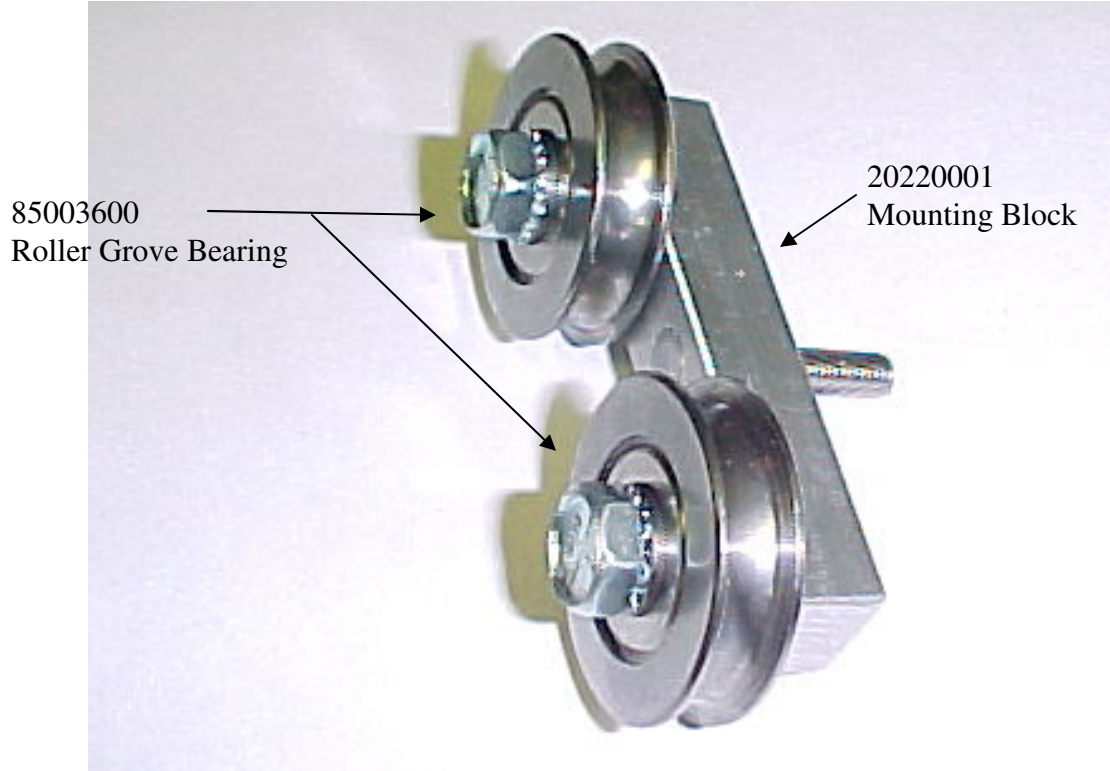

FOR ELECTRIC ONLY

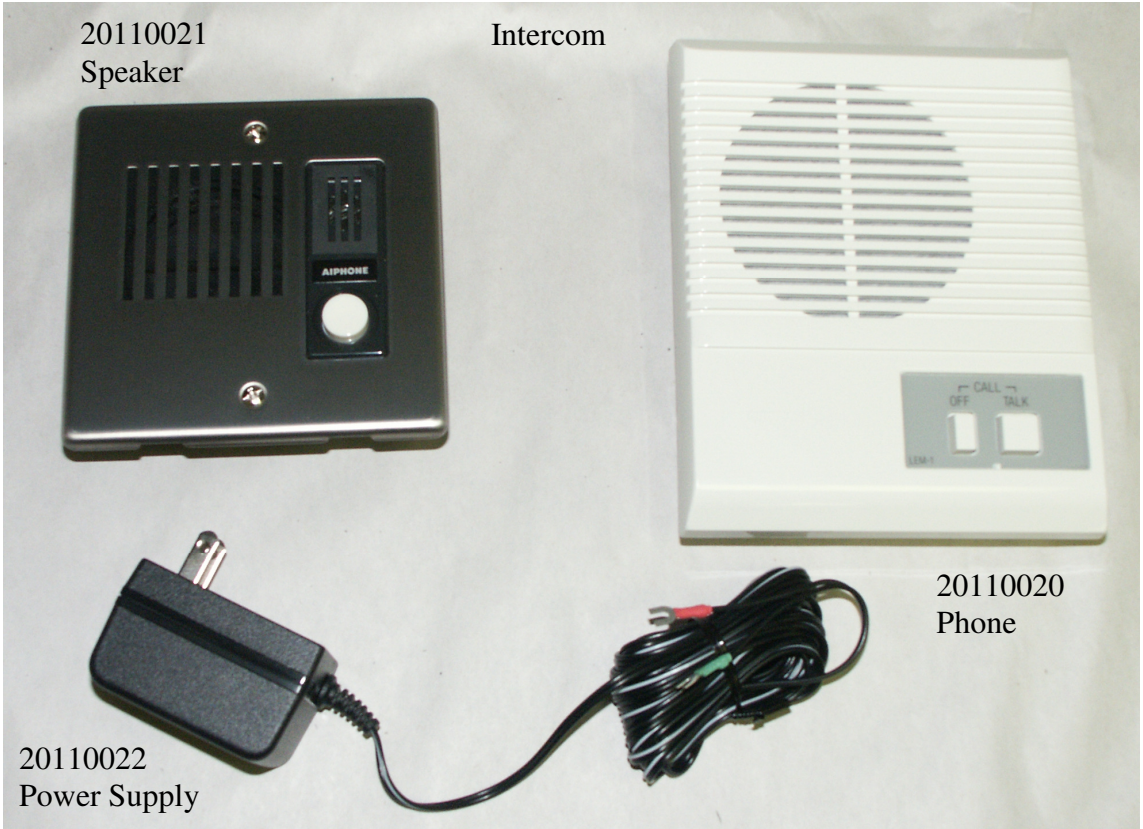
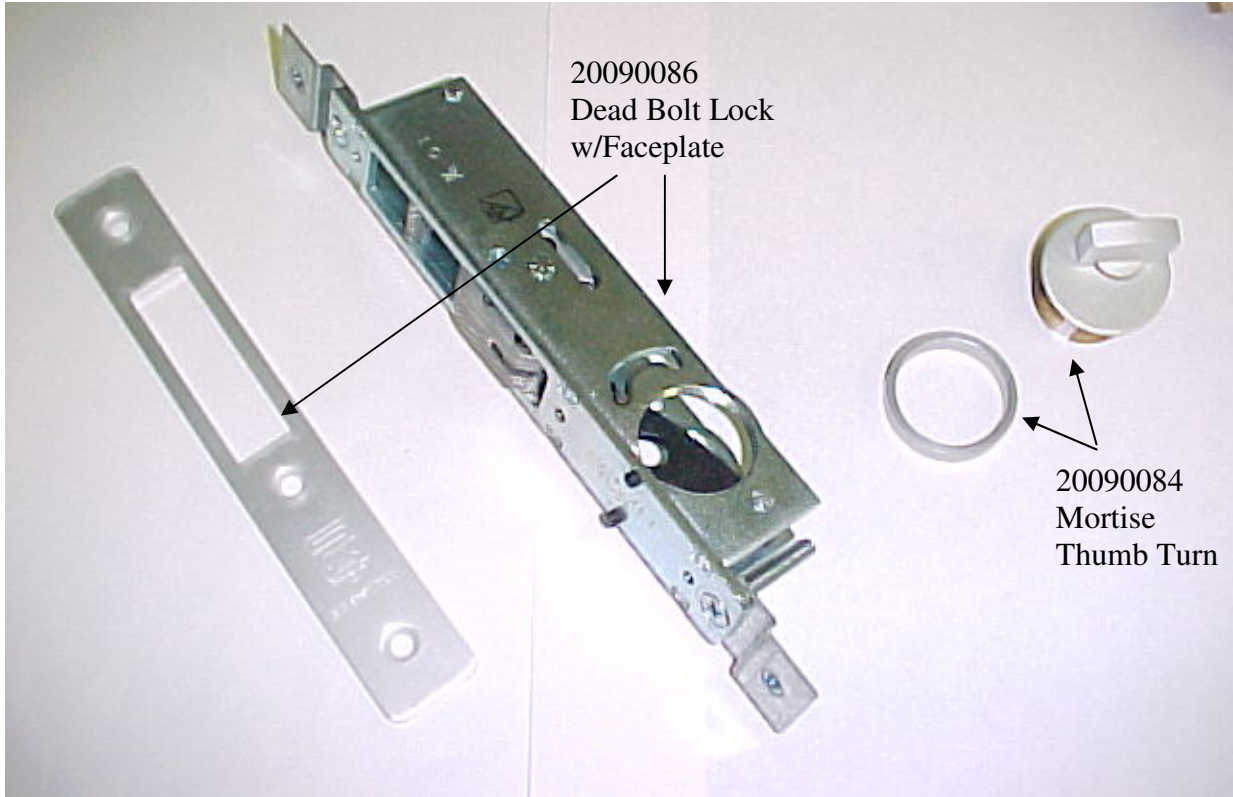

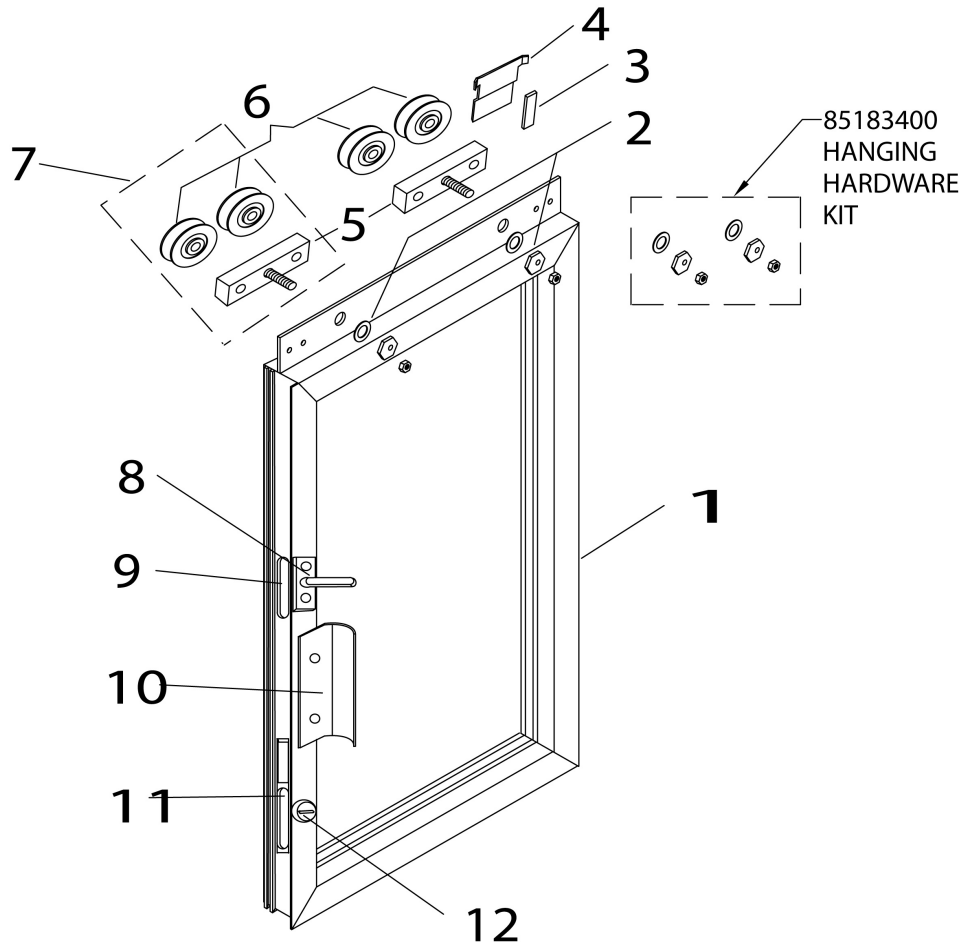

REF ID #	PART NUMBER	DESCRIPTION	REF ID #	PART NUMBER	DESCRIPTION
1	See Parts List	Door Assembly	8	85004500	Latch Lock Thumb Turn
2	85183400	Hanging Hardware Kit	9	20091180	Latch Lock Electric
3		Cable Clamp	9	85004400	Latch Lock Self Closing
4	66122300	Chain and Micro Switch Bracket	10	65103300	Door Handle
5	20220001	Mounting Block	11	20090084	Lock – Mortise
6	85003600	Roller Groove Bearing Kit (1 Bearing w/ Screws)	12	20090086 Electric Only	Lock Assembly Dead Bolt w/Faceplate
7	85003200	Roller Block Assembly			

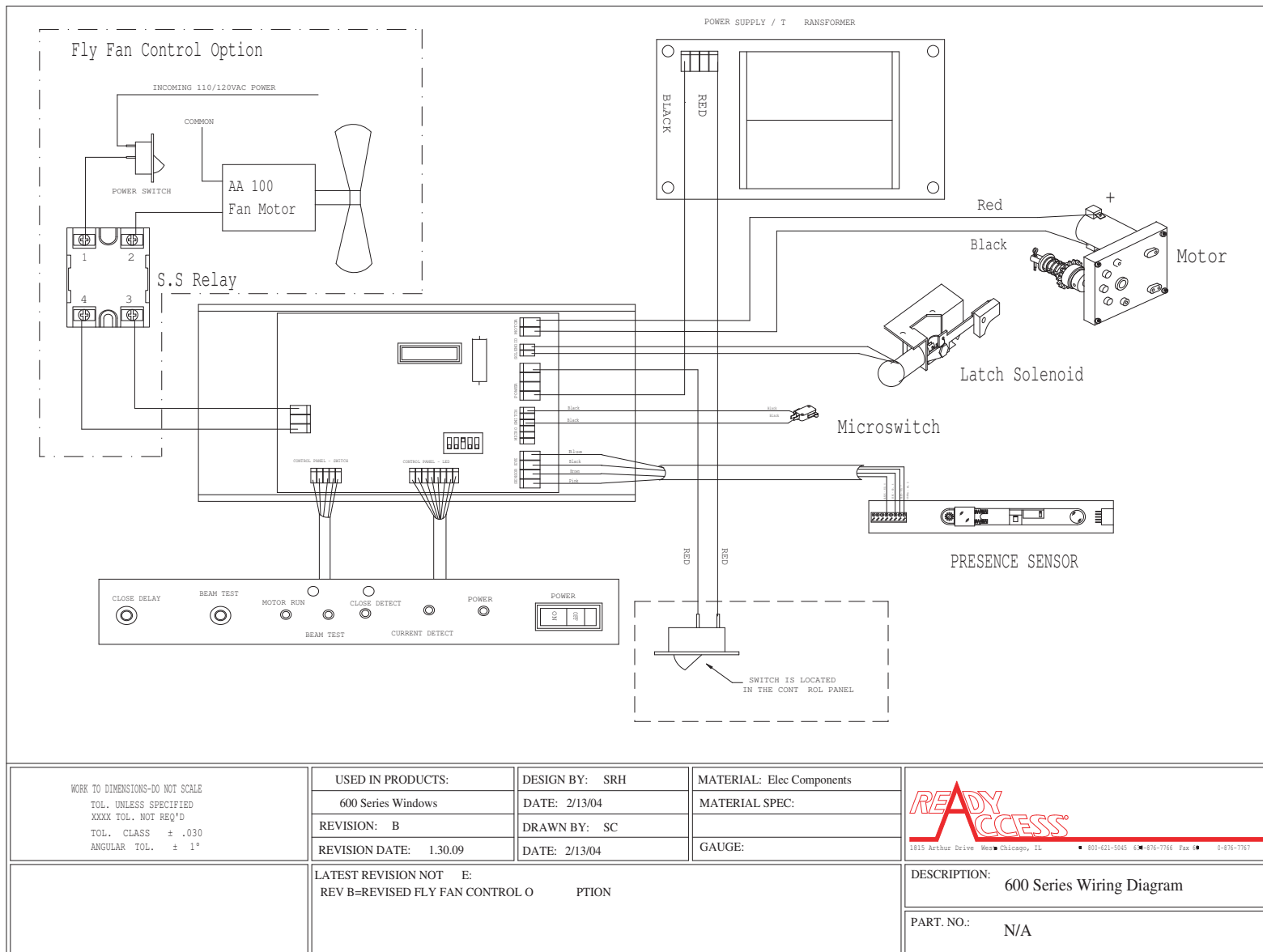

Note: Serial #103801 to present, 600 Series Windows have 2 Micro switches.

Appendix A Adjusting or Re-hanging the Door

The distance of the door(s) above the mullion or counter top is adjusted by turning the eccentric nuts located in the corners at the top of each door. The exploded view of the assembly is shown in Figure 1 below.

When a door has dropped, such that it impedes the movement of the door, it is necessary to re-adjust the door to a given distance above the counter top. This is accomplished by loosening the two Locking / Eccentric Nut combinations at the top of each door. Loosening the small locking nuts allows the door to drop down and rest on the counter top.

Slide the door inward to the closed position and lock using the night lock. Insert two shims about 0.100" in thickness under each door. One at each end of the door is suggested. A standard coffee stir or a tongue depressor is a bout 0.100" thick. This allows the door to set at a preset distance off the counter top.

Starting with one of the Locking / Eccentric Nut combinations turn the eccentric nut until you feel resistance and/or notice that the door is beginning to rise. Keeping the eccentric nut in that position, tighten the locking nut down to approximately 30 lbs/in² of torque.

Repeat the above step for each of the remaining Locking / Eccentric Nut combinations. Remove the shims. The door should now be at the proper height as well as being square with each other.

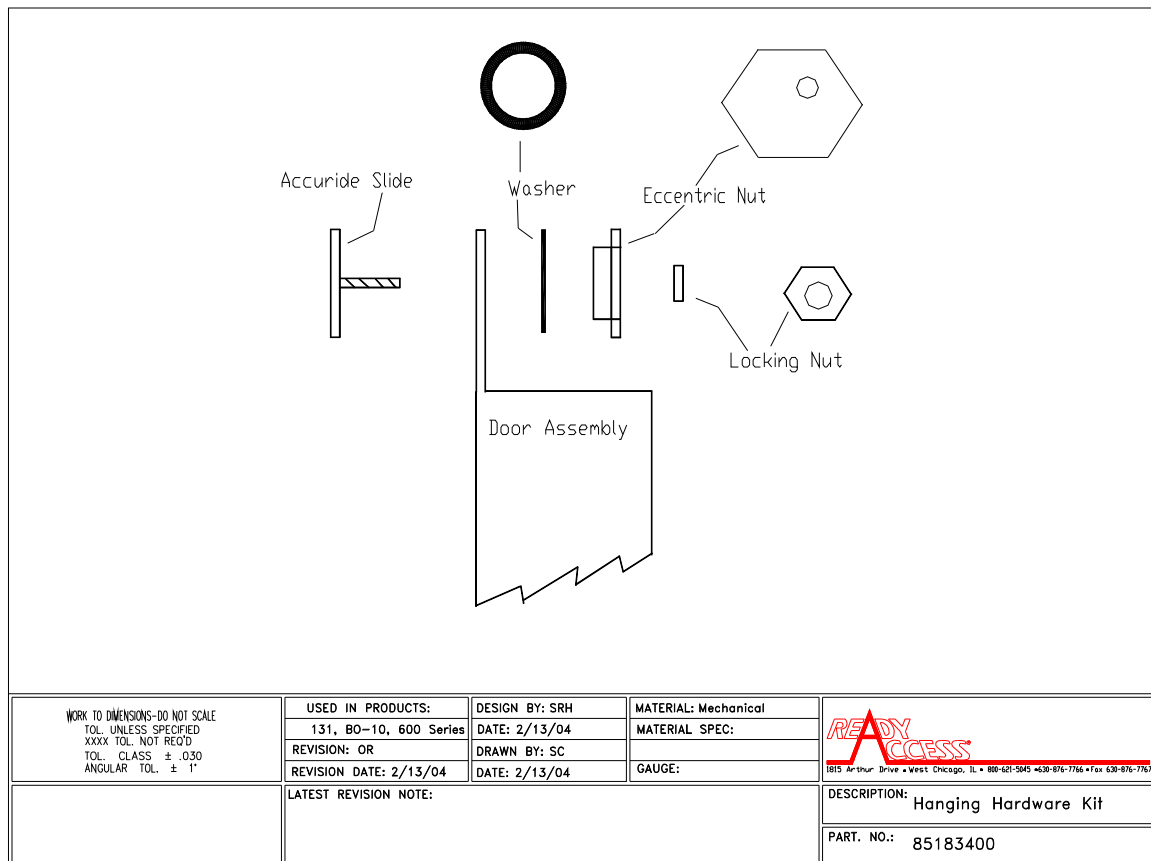

**READY
ACCESS[®]**



COVENANT
Security Equipment